



12 Megapixel CMOS Monochrome Machine Vision Camera with Camera Link

CLEVERDRAGON 12MP



Key Features

12 MEGAPIXEL IMAGING: Toshiba Teli CleverDragon (Model Number CSC12M25BMP19) features a 12 Megapixel 1.9 inch CMOS monochrome sensor to capture 4096 (H) x 3072 (V) pixel resolution images in unprecedented detail. It is the optimal platform for integrators and OEMs designing systems for high-speed machine vision, parts inspection and robotics.

HIGH-SPEED, FULL FRAME READOUT: The CSC12M25BMP19 camera can capture images at full frame at speeds up to 25 frames-per-second.

WINDOW-OF-INTEREST: Faster frame speed is possible via the Window of Interest (WOI) programmable, partial scanning mode. WOI can be programmed to display a maximum of 28 square windows within one image and then allow the user to select only select windows to be read out.

CAMERA LINK: Based on the Camera Link standard (10/8bit selectable), the camera can be immediately integrated into new and existing imaging systems without requiring special cables or frame grabbers.

FEATURE RICH PERFORMANCE: The camera also has large square pixels (6.0 μ m x 6.0 μ m), 4:3 aspect ratio, binning, a wide dynamic range (multi-slope), and random trigger shutter.

Specifications

MODEL	CSC12M25BMP19
Image sensor	CMOS Image sensor
Active pixel	4096 (H) x 3072 (V)
Active area	24.6mm (H) x 18.5mm (V) 1.9 type
Pixel size	6.0μm x 6.0μm
Scan method	Progressive
Aspect ratio	4:3
Video output	Camera Link
	Data 10 / 8 bit switchable
Frame rate	
All pixels reading	25fps (4096 x 3072)
Binning	2 (H) x 2 (V) at 30 fps (2048 x 1536)
Sub-sampling	50-200 fps
Sensitivity	2000 lx (F5.6)
Gain control	from 0 to 18 dB
Gamma	1.0
Input signal	LVDS
Electronic shutter	Global shutter, RDM shutter
Random trigger shutter	ON/OFF change
Fixed mode	Exposure depends on shutter speed
Pulse width mode	Exposure depends on pulse width
Shutter speed	
All pixels reading	1/20,000 to 2 sec
Binning	1/20,000 to 2 sec
Sub-sampling	1/20,000 to 2 sec
Window of interest	1-28 windows
Set position	H: Integral multiples of 128 column V: Integral multiples of 1 row
Size of window	H: Integral multiples of 128 column V: Integral multiples of 1 row
Power consumption	Approx 6W (in DC12V)
Lens mount	TFL-II mount
Flange back	17.5mm
External dimension	75(W) x 75(H) x 69.5(D)mm
Weight	Approx. 400g
Safety standards	CE, FCC



Typical Applications

Video image capture applications for this camera include high-speed, detail intensive machine vision, factory automation, robotics, inspection, medical/scientific and many others.

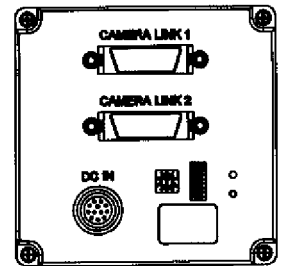
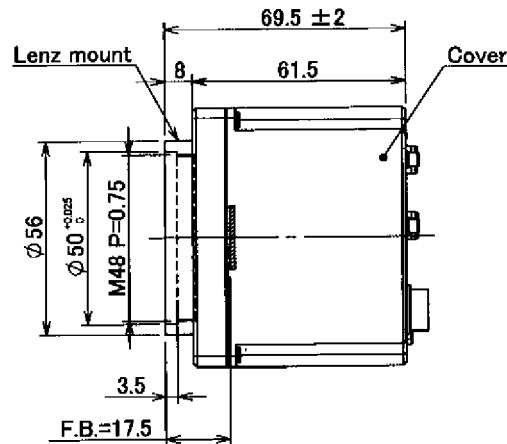
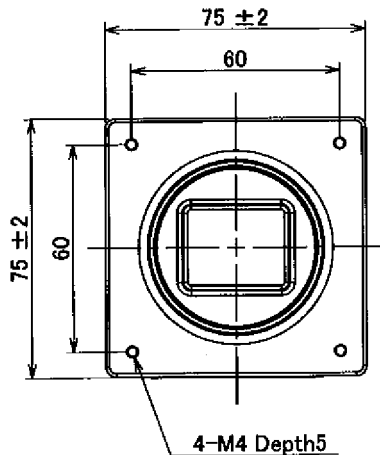
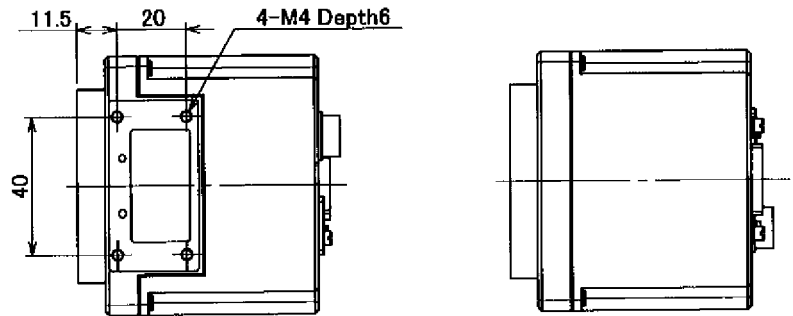

TOSHIBA TELI CORPORATION
 7-1, 4-chome Asahigaoka
 Hino-shi, Toyko 191-0065 Japan
 TEL: +81-042-589-8771
 FAX: +81-042-589-8774
 www.toshiba-teli.co.jp

TOSHIBA TELI AMERICA, INC.
 33 Hammond, Suite 211
 Irvine, California 92618 USA
 TEL: +1-949-770-TELI(8354)
 FAX: +1-949-206-0210
 www.toshiba-teli.com

