

SONY®



# LUMA Family Catalog 2008

Professional LCD Monitor

**LUMA**  
Professional LCD Monitor

# A Comprehensive Line of LCD Monitors– the LUMA

Since its introduction in 2003, Sony's LUMA™ Series of professional LCD monitors has been offered in a variety of types and sizes, suiting applications in the studio and in the field. Building on the long history as a leading supplier of CRT HD monitors, and more recently LCD HD monitors, Sony now extends the LUMA Series by adding another two HD-compatible LCD monitors: the LMD-4250W and LMD-1750W.

These high-grade type LUMA monitors incorporate a 10-bit DSP (Digital Signal Processor) and Sony's ChromaTRU™ color matching technology for high-end picture monitoring.

As with other high-grade type LUMA monitors, the LMD-4250W and LMD-1750W are SD/HD compatible, and accept PC signals via a digital DVI-D or an analog HD-15 interface. They offer a variety of analog and digital video interfaces, from composite up to HD-SDI.

At the same time, the LUMA Series continues to support the well-accepted entry-level type LUMA monitors, as well as the hand-held type and multi-display type LUMA monitors for a variety of picture monitoring needs and styles.

With the strength of Sony's video expertise, the LUMA Series is sure to meet a variety of picture monitoring applications from broadcast and postproduction to medical and surveillance applications.

■ [Entry-level Type](#) [Page 10](#)



■ [Multi-display Type](#) [Page 14](#)

# True Professional Series from Sony



■ High-grade Type  
Page 4



■ Handheld Type Page 12

# High-grade Type

---

The LMD-4250W, LMD-2450W, LMD-2050W, and LMD-1750W are all positioned at the top of the LUMA Series. They offer the latest DSP engine, the market-proven ChromaTRU color matching technology, and the high functionality for which Sony professional video monitors are renowned. These monitors accept a variety of signals in both analog and digital, and HD and SD formats. Digital HD-SDI and SD-SDI interfaces are provided as options. The LMD-4250W, LMD-2450W, LMD-2050W, and LMD-1750W are the best-suited LCD monitors for broadcast and postproduction applications.



LMD-4250W



LMD-1750W



LMD-2450W



LMD-2050W

## Four Panel Sizes

The high-grade type LUMA monitors are offered in four panel sizes between 42-inch and 17-inch (viewable area, measured diagonally).

Model Types

	Panel Resolution	Panel Aspect Ratio	Panel Size*	Desktop Stand	Mounting Holes (mm)	
					19-inch Rack	VESA® Mounting
<b>LMD-4250W</b>	1920 x 1080	16:9	42-inch	N/A	N/A	400 x 400
<b>LMD-2450W</b>	1920 x 1200	16:10	24-inch	Supplied	N/A	100 x 100
<b>LMD-2050W</b>	1680 x 1050	16:10	20-inch	Supplied	Optional MB-529	100 x 100
<b>LMD-1750W</b>	1280 x 768	15:9	17-inch	Optional SU-561	Optional MB-530	75 x 75, 100 x 100

\* Viewable area, measured diagonally.

## Input Versatility

### Multi-format Signal Support

The high-grade type LUMA monitors accept almost any SD or HD video format, both analog and digital. These include composite NTSC and PAL, component 480/60i and 575/50i, progressive 480/60P and 576/50P, and high definition 1080/60i, 1080/50i, 720/60P, 1080/24P, 1080/25P, and 1080/30P. They also accept 1080/24PsF and 1080/25PsF.

Standard interfaces include analog composite (NTSC/PAL), 525i/625i component and RGB, and Y/C. Additional inputs can be added by using option boards. Digital interfaces including HD-SDI and SD-SDI are also offered as optional boards, to meet budgetary and user needs.

The high-grade type LUMA monitors also accept various types of analog and digital computer signal via the standard HD-15 and DVI-D\*1 interfaces, respectively. With their high-performance scan converters, these monitors can display PC signals from VGA to WUXGA\*2.

\*1 Both 1080/50P and 1080/60P signals are accepted. The images are down-converted for display on the LMD-2050W and LMD-1750W.

\*2 WUXGA images are not accepted by the LMD-4250W and LMD-2050W. Images ranging from WSXGA+ to 1920 x 1080 are down-converted for display on the LMD-2050W.

### Input Signals/Input Adaptors

Video Signal Formats	Input Signal				Interface					
	Total Line	Active Line	Aspect Ratio	Frame rate*1	Composite Y/C	RGB Component	SDI 4:2:2	SD-SDI HD-SDI	Composite Y/C	RGB Component
					Standard	Optional BKM-220D	Optional BKM-244CC BKM-243HS	Optional BKM-227W	Optional BKM-229X	
<b>575/50i (PAL)</b>	625	575	16:9 & 4:3	25	○	○	○	○	○	○
<b>480/60i (NTSC)</b>	525	483	16:9 & 4:3	30	○	○	○	○	○	○
<b>576/50p</b>	625	576	16:9 & 4:3	50	—	○	—	—	—	○
<b>480/60p</b>	525	483	16:9 & 4:3	60	—	○	—	—	—	○
<b>1080/24PsF</b>	1125	1080	16:9	24	—	○*2	—	○	—	○*2
<b>1080/25PsF</b>	1125	1080	16:9	25	—	○*2	—	○	—	○*2
<b>1080/24p</b>	1125	1080	16:9	24	—	○*2	—	○	—	○*2
<b>1080/25p</b>	1125	1080	16:9	25	—	○*2	—	○	—	○*2
<b>1080/30p</b>	1125	1080	16:9	30	—	○*2	—	○	—	○*2
<b>1080/50i</b>	1125	1080	16:9	25	—	○	—	○	—	○
<b>1080/60i</b>	1125	1080	16:9	30	—	○	—	○	—	○
<b>720/50p</b>	750	720	16:9	50	—	○*2	—	○	—	○*2
<b>720/60p</b>	750	720	16:9	60	—	○	—	○	—	○

\*1 Compatible with 1/1.001 \*2 For component input only



# High-grade Type

## Signal-interface Options

The high-grade type LUMA monitors accept HD-SDI and SD-SDI signals via the following optional input adaptors:



### Connector Panel

#### BKM-244CC

##### HD/SD-SDI Closed Caption Adaptor\*

- HD-SDI/SD-SDI signal input (x2)
- HD-SDI/SD-SDI monitor output (x1)
- Power consumption: 3.8 W

\*Both EIA 608 and EIA 708 Closed caption decoders are equipped.

\*HD-SDI and SD-SDI signals are automatically detected.

BKM-244CC

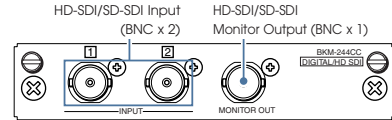

#### BKM-243HS

##### HD-SDI/SD-SDI Input Adaptor\*

- HD-SDI/SD-SDI signal input (x2)
- HD-SDI/SD-SDI monitor output (x1)
- Power consumption: 2.0 W

\*HD-SDI and SD-SDI signals are automatically detected.

BKM-243HS

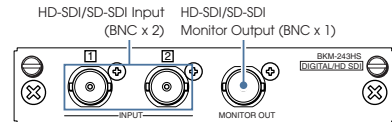

#### BKM-220D

##### SD-SDI 4:2:2 Input Adaptor\*

- SD-SDI signal input (x2)
- SD-SDI monitor output (x1)
- Power consumption: 1.5 W

\*Embedded audio is supported.

BKM-220D

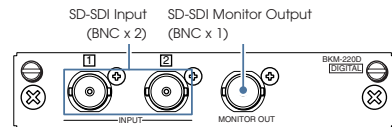

#### BKM-229X

##### Analog Component Adaptor

- RGB/ Y/Pb/Pr input connector (x1)
- EXT SYNC (x1)
- Power consumption: 4.0 W

BKM-229X

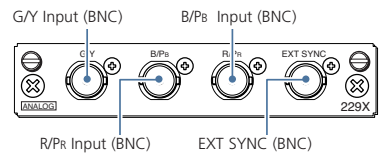

#### BKM-227W

##### NTSC/PAL Input Adaptor

- Composite input/output (x1)
- Y/C input/output (x1)
- Power consumption: 1.8 W

BKM-227W

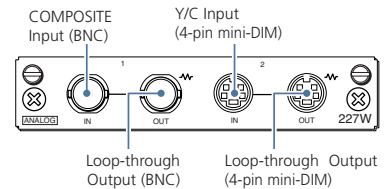

LMD-4250W Connector Panel and Option Slots

LMD-2450W/LMD-2050W Option Slots



LMD-2450W/LMD-2050W Connector Panel

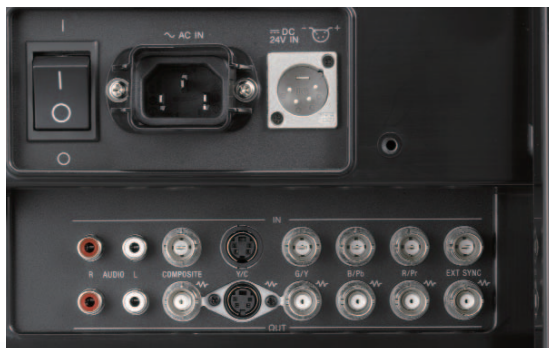

LMD-1750W Connector Panel and Option Slots



## Preset Computer Input Frequencies

The high-grade type LUMA monitors are factory preset to accept the following typical computer input signal frequencies:

### HD15 Input Signal Format

Resolution	H Total	H Addr.	V Total	V Addr.	Dot Clock [MHz]	fH [kHz]	fV [Hz]	Sync Polarity		LMD-4250W	LMD-2450W	LMD-2050W	LMD-1750W
								Horizontal	Vertical				
640x480 @60Hz*	800	640	525	480	25.175	31.469	59.940	N	N	○	○	○	○
640x480 @60Hz	800	640	494	480	23.625	29.531	59.780	P	N	○	○	○	○
720x400 @70Hz* <sup>3</sup>	900	720	449	400	28.322	31.469	70.087	N	P	○	○	○	○
800x600 @56Hz*	1024	800	625	600	36.000	35.156	56.250	P	P	○	○	○	○
800x600 @60Hz*	1056	800	628	600	40.000	37.879	60.317	P	P	○	○	○	○
800x600 @60Hz	960	800	618	600	35.500	36.979	59.837	P	N	○	○	○	○
800x600 @72Hz*	1040	800	666	600	50.000	48.077	72.188	P	P	○	○	○	○
800x600 @75Hz*	1056	800	625	600	49.500	46.875	75.000	P	P	○	○	○	○
800x600 @85Hz*	1048	800	631	600	56.250	53.674	85.061	P	P	○	○	○	○
1024x768 @60Hz*	1344	1024	806	768	65.000	48.363	60.004	N	N	○	○	○	○
1024x768 @60Hz	1184	1024	790	768	56.000	47.297	59.870	P	N	○	○	○	○
1024x768 @70Hz*	1328	1024	806	768	75.000	56.476	70.069	N	N	○	○	○	○
1024x768 @75Hz*	1312	1024	800	768	78.750	60.023	75.029	P	P	○	○	○	○
1024x768 @85Hz*	1376	1024	808	768	94.500	68.677	84.997	P	P	○	○	○	○
1152x864 @75Hz*	1600	1152	900	864	108.000	67.500	75.000	P	P	○	○	○	—
1280x768 @50Hz	1648	1280	791	768	65.125	39.518	49.959	N	P	○	○	○	○
1280x768 @60Hz	1680	1280	795	768	80.125	47.693	59.992	N	P	○	○	○	○
1280x768 @60Hz	1440	1280	790	768	68.250	47.396	59.995	P	N	○	○	○	○
1280x768 @75Hz	1712	1280	802	768	102.875	60.091	74.926	N	P	○	○	○	○
1280x800 @60Hz* <sup>1</sup>	—	—	—	—	68.900	48.935	59.969	N	N	○	○	○	○
1280x960 @60Hz*	1800	1280	1000	960	108.000	60.000	60.000	P	P	○	○	○	—
1280x960 @60Hz	1440	1280	988	960	85.250	59.201	59.920	P	N	○	○	—	—
1280x1024 @60Hz*	1688	1280	1066	1024	108.000	63.981	60.020	P	P	○	○	○	○
1280x1024 @60Hz	1440	1280	1054	1024	91.000	63.194	59.957	P	N	○	○	○	○
1360x768 @50Hz	1760	1360	791	768	69.500	39.489	49.922	N	P	○	○	○	—
1360x768 @60Hz	1776	1360	768	768	84.625	47.649	59.936	N	P	○	○	○	—
1360x768 @60Hz	1520	1360	790	768	72.000	47.368	59.960	P	N	○	○	○	—
1600x1200 @50Hz	2144	1600	1235	1200	132.375	61.742	49.994	N	P	—	○	—	—
1600x1200 @60Hz*	2160	1600	1250	1200	162.000	75.000	60.000	P	P	—	○	—	—
1600x1200 @60Hz	1760	1600	1235	1200	130.375	74.077	59.981	P	N	—	○	—	—
1920x1080 @50Hz	2544	1920	1112	1080	141.375	55.572	49.975	N	P	○	○	○	○
1920x1200 @50Hz	2560	1920	1235	1200	158.000	61.719	49.975	N	P	—	○	—	—
1920x1080 @60Hz	2080	1920	1111	1080	138.625	66.647	59.988	P	N	○	○	○	○
1920x1200 @60Hz	2080	1920	1235	1200	154.125	74.099	59.999	P	N	—	○	—	—
1920x1200 @60Hz* <sup>2</sup>	2120	1920	1212	1200	154.000	74.642	59.935	P	P	—	○	—	—

=VESA-DMT     
  =VESA-CVT VCRT  
 N = Negative      P = Positive      \* SOG      \*<sup>1</sup> Anycast Station      \*<sup>2</sup> Sony SDM-P232W Digital      \*<sup>3</sup> Matrix

# High-grade Type

## Superb Picture Performance

### High Purity Color Filters

The high-grade type LUMA monitors use precisely manufactured RGB color filters, allowing the reproduction of colors with stunning depth and saturation to create highly natural images.

### Accurate Gamma and Stable White Balance - ChromaTRU Color Processing



For an extra level of color reproduction accuracy, every LCD panel used in the high-grade type LUMA monitors is precisely color calibrated at the factory, providing characteristics consistent with those of CRT displays.

The colorimetry of an LCD display, by nature, can exhibit inaccurate R, G, B color coordinates and unbalanced R, G, B gamma curves, which can make precise color matching between multiple monitors a challenge. These are also the primary reasons why LCD color tone can slightly differ from CRT tone. The high-grade type LUMA monitors solve this problem by precisely calibrating each LCD panel's light output so that the R, G, B color coordinates are virtually the same as those of a CRT monitor. A second calibration is further applied so that white balance is maintained at a consistent color temperature throughout all grayscale levels. The result of these precise calibrations is color reproduction reminiscent of Sony's CRT displays.

### Sophisticated I/P Conversion

The high-grade type LUMA monitors use a motion adaptive I/P conversion process to achieve conversion results that are optimized to the picture content - whether it is static or dynamic. Highly accurate I/P conversion is provided regardless of signal resolution, for example, whether the input is HD or SD.

### Excellent Brightness and Contrast

The high-grade type LUMA monitors provide high-brightness, high-contrast images by utilizing super-wide aperture LCD panels.

### Extremely Wide Viewing Angle

The high-grade type LUMA monitors offer the most stable images within the LUMA Series when viewed from various angles. They offer wide viewing angles both horizontally and vertically, with virtually no reduction in picture contrast, color saturation, and hue shift. This allows precise images to be clearly viewed from various positions and angles - a critical requirement in professional video monitoring.

The CIE  $u'$   $v'$  chart is used to evaluate the light output of display devices. In this diagram, the raw light output of a LUMA LCD panel is compared with that of a CRT from Sony. The triangular areas show their different color reproduction capabilities (Color Space). The green and red dots indicate the color of light output from the LUMA LCD panel and from the CRT for certain RGB input signals. Note that the same light color is not obtained for the same video input. The ChromaTRU process, on the other hand, reproduces consistent light output extremely close to that of a CRT.

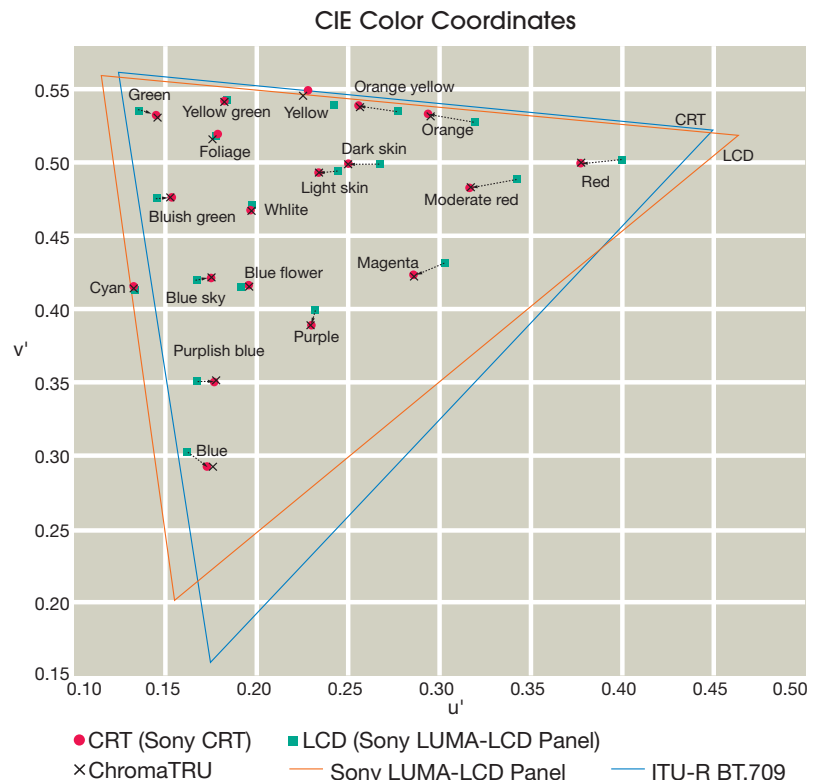

## Operational Convenience

### Advanced Marker Settings

The high-grade type LUMA monitors can display various area markers, including a center marker, aspect markers, and a safety zone marker. The brightness of these markers can be selected from three different levels: white, gray, and dark gray. Users can also select either a black or gray matte to fill the outer area of the aspect markers. These flexible marker controls, together with the choice of many different aspect markers, make the high-grade type LUMA monitors extremely convenient display devices for a variety of shooting scenarios – from standard video acquisition to digital cinematography.

### Marker Variation

	16:9 Mode	4:3 Mode
Aspect Marker	4:3, 15:9, 14:9, 13:9, 1.85:1, 2.35:1, 1.85:1 & 4:3	16:9
Center Marker	O	
Safety Area	80%, 85%, 88%, 90%, 93%	

### Color Temperature

Color temperatures of 9300k, or 6500k, or a user preset setting can be selected.

### Selectable Scan Size for Video Input and Aspect Ratio

The scan size can be selected between 5% over scan and 0% scan modes. The aspect ratio can be switched between 16:9 and 4:3 according to the input signal.

### Three-color Tally

The LMD-2450W, LMD-2050W, and LMD-1750W come equipped with a tally lamp that can be lit via a parallel remote connector. The status of the signal displayed on the monitor can be identified by the tally color – red, green, or amber.

### Smart APA (Auto Pixel Alignment) for Computer Input

The image size can be automatically adjusted to its optimal setting with the one-touch APA key.

### Parallel and Serial Remote Control

The high-grade type LUMA monitors can be controlled remotely via a parallel and serial remote connector. There are 38 functions (35 functions for LMD-4250W) in the parallel remote menu (such as the ability to switch input signals), of which eight can be allocated to the connector. The serial remote controls are supported via the Ethernet and RS-232C command.

### Stereo Audio Monitoring

The high-grade type LUMA monitors are equipped with stereo speakers (1.0 W + 1.0 W), which enable the user to monitor audio.

### Protected Controls

The key-inhibit function helps prevent inadvertent operation from the control panel.

### Closed-Caption Decoder

The high-grade type LUMA monitors are equipped with closed caption decoders. The closed caption information embedded in EIA608 and EIA708\* can be decoded for display.

\*For EIA708, the optional Closed Caption Adaptor BKM-244CC is required.

## Convenient Installation

### Mounting Flexibility

#### Mountable in a 19-inch EIA Standard Rack (LMD-2050W and LMD-1750W)

Although wider than a 19-inch rack, the LMD-2050W (8U high) can be rack mounted using the optional MB-529 Mounting Bracket. The LMD-1750W (7U high) can also be rack mounted using the optional MB-530 Mounting Bracket.

#### VESA® Mounting

Complying with VESA standards, both the LMD-2450W, LMD-2050W and LMD-1750W can easily be mounted on a wall or ceiling.

## Other Features

- WFM and Audio Level Meter\* Windows (LMD-2450W, LMD-2050W, and LMD-1750W)  
\* Only embedded audio is supported.
- Picture by Picture mode
- H/V Delay Function
- ACC Off
- DC Operation (24V: LMD-2450W and LMD-2050W, 12V: LMD-1750W)
- Setup Level for Analog Component and NTSC signal
- Sub Control on Contrast, Chroma, Phase, and Brightness
- Blue-Only Mode
- Monochrome Mode
- Auto Chroma/Phase Setup
- DVI-D Input
- Power-saving Function (computer input only)
- DDC-2B

# Entry-level Type

The LMD-2030W, LMD-1420 and LMD-1410 offer the best quality-per-cost balance for entry-level applications. The LMD-2030W can accept HD signals via its HDMI interface or analog component connectors. The LMD-1420 and LMD-1410 are exclusively designed for SD monitoring. All of these models provide the user-friendly features proven in Sony professional monitors for convenient monitoring in wedding and event videography, and many other applications.

## Two Panel Sizes

The entry-level type LUMA monitors are offered in three versions: the LMD-1410 which provides the basic features for SD professional picture monitoring, the LMD-1420 for more advanced SD monitoring, and the LMD-2030W with an HD monitoring capability.

### Model Types

	Panel Resolution	Panel Aspect Ratio	Panel Size*	Desktop Stand	Mounting Holes (mm)	
					19-inch Rack	VESA Mounting
<b>LMD-2030W</b>	1680 x 1050	Wide	20-inch	Supplied	Optional MB-529	100 x 100
<b>LMD-1420</b>	640 x 480	4:3	14-inch	Supplied	Optional MB-526	100 x 100
<b>LMD-1410</b>	640 x 480	4:3	14-inch	Supplied	Optional MB-526	100 x 100

\* Viewable area measured diagonally.



LMD-2030W



LMD-1420



LMD-1410

## Input Versatility

All entry-level type LUMA monitors come equipped with a full range of analog SD inputs including analog composite NTSC and PAL, Y/C (S-Video), and 525i/625i component and RGB.

The LMD-2030W and LMD-1420 further handle SD-SDI input by using the optional BKM-320D SD-SDI input adaptor. Furthermore, the LMD-2030W offers an HD signal input capability via its standard HDMI and Analog Component interface.

	Interface			
	Composite/Y/C	RGB/Component	SD-SDI	HDMI
<b>LMD-2030W</b>	○	○	Optional BKM-320D	○
<b>LMD-1420</b>	○	○		—
<b>LMD-1410</b>	○	○	—	—

System	Input Signal			Interface			
	Total Line	Active Line	Aspect Ratio	Composite Y/C	RGB Component	SD-SDI	HDMI
				Standard		Optional BKM-320D	Standard
<b>Model</b>				LMD-2030W LMD-1420 LMD-1410	LMD-2030W LMD-1420 LMD-1410	LMD-2030W LMD-1420	LMD-2030W
<b>575/50i (PAL)</b>	625	575	16:9/4:3	○	○	○	○*3
<b>480/60i (NTSC)*1</b>	525	483	16:9/4:3	○	○	○	○*4
<b>576/50P</b>	625	576	16:9/4:3	—	○*5	—	○
<b>480/60P</b>	525	483	16:9/4:3	—	○*5	—	○
<b>1080/24PsF*1</b>	1125	1080	16:9	—	○*2*5	—	—
<b>1080/25PsF</b>	1125	1080	16:9	—	○*2*5	—	—
<b>1080/24P*1</b>	1125	1080	16:9	—	○*2*5	—	○
<b>1080/25P</b>	1125	1080	16:9	—	○*2*5	—	○
<b>1080/30P*1</b>	1125	1080	16:9	—	○*2*5	—	○
<b>1080/50i</b>	1125	1080	16:9	—	○*2*5	—	○
<b>1080/60i*1</b>	1125	1080	16:9	—	○*5	—	○
<b>720/50P</b>	750	720	16:9	—	○*2*5	—	○
<b>720/60P*1</b>	750	720	16:9	—	○*5	—	○

\*1 The frame rate is also compatible with 1/1.001 frame rates. \*2 Component signals only.

\*3 720 (1440) x 576i @ 50 Hz. \*4 720 (1440) x 480i @ 59.94/60 Hz. \*5 LMD-2030W only.

## LMD-2030W Connector Panel

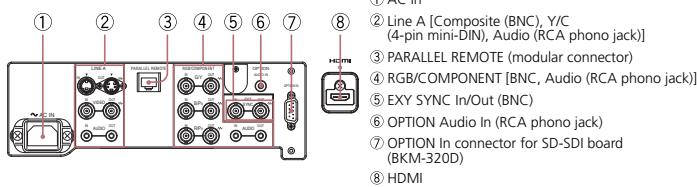

- ① AC In
- ② Line A [Composite (BNC), Y/C (4-pin mini-DIN), Audio (RCA phono jack)]
- ③ PARALLEL REMOTE (modular connector)
- ④ RGB/COMPONENT [BNC, Audio (RCA phono jack)]
- ⑤ EXY SYNC In/Out (BNC)
- ⑥ OPTION Audio In (RCA phono jack)
- ⑦ OPTION In connector for SD-SDI board (BKM-320D)
- ⑧ HDMI

## LMD-1420 Connector Panel

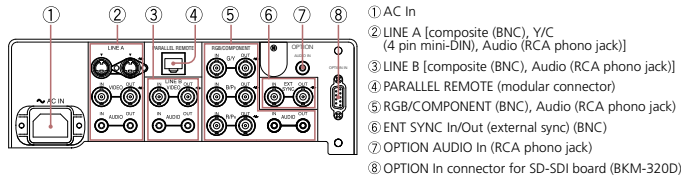

- ① AC In
- ② LINE A [composite (BNC), Y/C (4 pin mini-DIN), Audio (RCA phono jack)]
- ③ LINE B [composite (BNC), Audio (RCA phono jack)]
- ④ PARALLEL REMOTE (modular connector)
- ⑤ RGB/COMPONENT (BNC), Audio (RCA phono jack)
- ⑥ ENT SYNC In/Out (external sync) (BNC)
- ⑦ OPTION AUDIO In (RCA phono jack)
- ⑧ OPTION In connector for SD-SDI board (BKM-320D)

## LMD-1410 Connector Panel

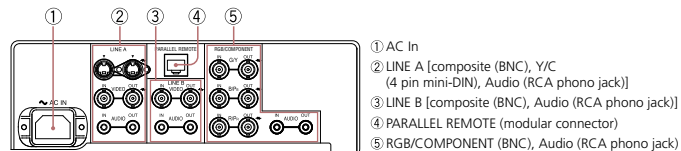

- ① AC In
- ② LINE A [composite (BNC), Y/C (4 pin mini-DIN), Audio (RCA phono jack)]
- ③ LINE B [composite (BNC), Audio (RCA phono jack)]
- ④ PARALLEL REMOTE (modular connector)
- ⑤ RGB/COMPONENT (BNC), Audio (RCA phono jack)

## High Picture Performance

### High Purity Color Filters

The entry-level type LUMA monitors come equipped with high-purity RGB color filters, allowing the reproduction of colors with stunning depth and saturation.

### Excellent Brightness and Contrast

The entry-level type LUMA monitors provide high-brightness, high-contrast images.

### Wide Viewing Angle

The LCD panels used in the entry-level type LUMA monitors provide a wide viewing angle of 178 degrees for the LMD-2030W, and 170 degrees for the LMD-1420 and LMD-1410, both horizontally and vertically, with minimal reduction in picture contrast. This allows images to be viewed from various positions and angles.

## Operational Convenience

### Advanced Marker Settings

The LMD-2030W and LMD-1420 can display various area markers, including a center marker and aspect markers. The brightness of these markers can be selected from three different levels: white, gray, and dark gray. Users can also select either a black or gray matte to fill the outer area of the aspect markers. These flexible marker controls, together with the choice of many different aspect markers, make these monitors extremely convenient display devices for a variety of shooting scenarios.

## Marker Variation

		16:9 Mode	4:3 Mode
Aspect Marker	LMD-2030W	4:3	16:9
	LMD-1420	4:3, 15:9, 14:9, 13:9	
Center Marker	LMD-2030W LMD-1420	O	
Safety Area	LMD-1420	80%, 85%, 88%, 90%, 93%	

## Color Temperature

The color temperature can be selected as 'high', 'low', or user preset.

## Selectable Scan Size for Video Input and Aspect Ratio

The scan size can be selected between 5% over-scan and -3% underscan modes. The aspect ratio can be switched between 16:9 and 4:3 according to the input signal.

## Three-color Tally

The LMD-2030W and LMD-1420 come equipped with a tally lamp that can be lit via a parallel remote connector. The status of the signal displayed on the monitor can be identified by the tally color - red, green, or amber.

## Parallel Remote Control

The entry-level type LUMA monitors can be controlled remotely via their parallel remote connectors. In the remote menu, there are 17 functions for the LMD-2030W and 25 for the LMD-1420 and LMD-1410 (such as the ability to switch input signals), of which seven can be allocated to the remote connector.

## Monaural Audio Monitoring

All entry-level type LUMA monitors are equipped with a speaker (0.5 W), which enables the user to monitor audio.

## Protected Controls

The key-inhibit function helps prevent inadvertent operation from the control panel.

## Convenient Installation

### Mounting Flexibility

#### Mountable in a 19-inch EIA Standard Rack

All entry-level type LUMA monitors can be mounted in a 19-inch EIA standard rack using optional mounting brackets. The 9U-high LMD-2030W uses the MB-529 Mounting Brackets, and the 7U-high LMD-1420 and LMD-1410 use the MB-526 Mounting Brackets.

#### VESA Mounting

Complying with VESA standards, these monitors can easily be mounted (100 x 100 mm pitch) on a wall or ceiling.

## Other Features

- Setup Level for Analog Component and NTSC signals
- Blue-Only Mode (LMD-2030W and LMD-1420 only)
- External Sync IN (LMD-2030W and LMD-1420 only)
- 4:3 Zoom (LMD-1420 only)

# Handheld Type

The handheld type LUMA monitors offer a great level of monitoring convenience in the field and the studio. Three models are available – the LMD-9050 with digital HD-SDI and SD-SDI input capability, the LMD-9030 focusing on SD-SDI video monitoring, and the LMD-9020, exclusively for analog video monitoring. All three models can display HD images using their analog component inputs.

Incorporating high-purity 9-inch\* panels, these monitors can be AC, DC, or battery driven so that they can be hand-held, situated on a desk, or mounted in standard racks. \* 8.4-inch viewable area measured diagonally.



LMD-9050



LMD-9030



LMD-9020

## Panel Type

	Panel Aspect Ratio	Panel Size*	Acceptable Format
LMD-9050	4:3	8.4-inch	Analog, HD-SDI/SD-SDI
LMD-9030	4:3	8.4-inch	Analog, SD-SDI
LMD-9020	4:3	8.4-inch	Analog

\* Viewable area measured diagonally.

## Input Versatility

To keep their units simple and clean, the handheld type LUMA monitors provide all inputs built-in as standard, instead of using optional input modules. For typical SD video monitoring, all three monitors offer interfaces for analog composite (NTSC/PAL), analog component/RGB (525/60i and 625/50i) and analog Y/C (S-Video). The LMD-9030 additionally offers SD-SDI input capability. The top-of-the-line LMD-9050 further provides a variety of digital progressive SD and HD formats through its HD-SDI interface\*. These include 480/60P and 576/50P, and high-definition 1080/60i, 1080/50i, 720/50P, 720/60P as well as 1080/24PsF.

\* The SD-SDI and HD-SDI inputs share the same BNC connectors, which offer automatic signal-type detection.

## Input Signals

System	Input Signal			Standard Interface			
	Total Lines	Active Line	Aspect Ratio	Composite Y/C (x 1)	RGB Component (x 1)	SDI (x2)	
	Model			LMD-9050	LMD-9050	LMD-9050	LMD-9050
				LMD-9030	LMD-9030	LMD-9030	LMD-9050
				LMD-9020	LMD-9020		
575/50i	625	575	16:9/4:3	○	○	○	—
480/60i*	525	483	16:9/4:3	○	○	○	—
480/60P	525	483	16:9/4:3	—	○	—	—
576/50P	625	576	16:9/4:3	—	○	—	—
1080/24PsF	1125	1080	16:9	—	○	—	○
1080/50i	1125	1080	16:9	—	○	—	○
1035/60i*	1125	1035	16:9	—	○	—	○
1080/60i*	1125	1080	16:9	—	○	—	○
720/50P	750	1080	16:9	—	○	—	○
720/60P	750	720	16:9	—	○	—	○

\* Also accepts 59.94 Hz field rate.

## High Picture Quality

### Excellent Brightness and Contrast

The handheld type LUMA monitors provide high-brightness and high-contrast images by using wide aperture LCD panels. In addition, the use of precisely manufactured RGB color filters allows these monitors to reproduce colors with stunning depth and saturation – creating highly natural images.

## Wide Viewing Angle

The LCD panels used in the handheld type LUMA monitors have a wide viewing angle of 170 degrees, both horizontally and vertically, with minimal reduction in picture contrast.

## AR (anti-reflection) Coated Protection Panel

The handheld type LUMA monitors use robust AR-coated protection layers, which minimize the chance of their panels being scratched during transportation – an extremely important criteria for use in the field or in any mobile application. The AR coating additionally has two unique characteristics: it provides a high transmission rate of the internal light source to keep the picture as bright as possible, and it keeps reflection from ambient light to a minimum. As a result, when used in bright lighting conditions, high contrast is still maintained even in dark areas of the picture.

## Operational Convenience

### ENG Kit VF-509

The handheld type LUMA monitors are a strategic choice for use in ENG and EFP field operations. When compared to CRT displays, the picture contrast of these monitors is affected less by ambient light, allowing clear images to be viewed even under strong sunlight. For further protection, the optional VF-509 ENG kit provides a Viewing Hood, Carrying Handle, and Connector Protector.

### 4:3/16:9 Switchable Display

The scan aspect ratio can be switched between 4:3 and 16:9.

### Selectable Scan Size

The scan size can be selected between 5% over-scan, 0%, and -3% underscan modes.

### LMD-9050, LMD-9030 and LMD-9020 Connector Panel

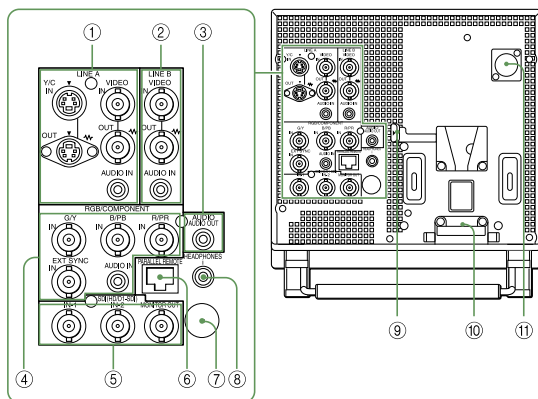

- ① Line A
  - Y/C In/Out (4-pin mini-DIN x 2)
  - Composite In/Out (BNC x 2)
  - Audio in (mini jack x 2)
- ② Line B
  - Composite In/Out (BNC x 2)
  - Audio In (mini jack)
- ③ Audio Out (mini jack)
- ④ RGB/Component
  - G/Y, B/Pb, R/Pr In (BNC x 3)
  - EXT Sync (BNC)
  - Audio In (mini jack)
- ⑤ SDI In/Out
  - (LMD-9050 : HD-SDI/SD-SDI In/Out)
  - (LMD-9030 : SD-SDI In/Out)
  - SDI-In (BNC x 2)
  - Monitor Out (BNC)
- ⑥ Parallel Remote (modular 8-pin)
- ⑦ Service Terminal
- ⑧ Headphones Jack
- ⑨ AC Adaptor Eject
- ⑩ AC Adaptor Attachment place
- ⑪ DC 12V In (XLR-type 4-pin)

## Advanced Marker Settings

The handheld type LUMA monitors can display various area markers, including a center marker and aspect markers. The brightness of these markers can be selected from three different levels: white, gray, and dark gray, and their widths can be selected from FINE, STANDARD, and BOLD. Users can also select either a black or gray matte to fill the outer area of the aspect markers. These flexible marker controls, together with the choice of many different aspect markers, make the handheld type LUMA monitors extremely convenient for a variety of shooting scenarios.

	16:9 Mode	4:3 Mode
Aspect Marker	4:3, 15:9, 14:9, 13:9, 1.85:1, 2.35:1, 1.85:1 & 4:3	16:9
Center Marker	O	

## Color Temperature/Gamma Selection

High/low color temperatures or user preset can be selected. A variety of gamma modes can also be selected.

## Three-color Tally

All handheld type LUMA monitors come equipped with a tally lamp that can be lit up via a parallel remote connector. The status of the signal displayed on the monitor can be identified by the tally color – red, green, or amber.

## Parallel Remote Control

The handheld type LUMA monitors can be controlled remotely via their parallel remote connectors. There are 27 functions in the remote menu (such as the ability to switch input signals), of which seven can be allocated to the connector.

## Monaural Audio Monitoring

All handheld type LUMA monitors are equipped with a speaker (0.5 W), which enables the user to monitor audio.

## Protected Controls

The key-inhibit function helps prevent inadvertent operations from the control panel.

## Convenient Installation

### Mounting Flexibility

The handheld type LUMA monitors are 5U high and half-rack wide. Using the optional MB-525 Mounting Bracket with a nine-step tilt capability, two units can be installed side-by-side in a 19-inch EIA standard rack.

## Other Features

- Setup Level for Analog Component and NTSC signal
- Sub Control on Contrast, Chroma, Phase, and Brightness
- Blue-only mode
- Power-saving Function
- Monochrome mode
- 4:3 Zoom

# Multi-display Type

The multi-display type LUMA monitors integrate high-quality LCD panels into an extremely thin and lightweight, 19-inch rack-mountable chassis. They can be AC or DC powered. These monitors are particularly handy for viewing multiple SD signal sources in space-confined environments – such as OB vehicles, machine rooms, and desktops – or any general application where multiple pictures must be viewed.



LMD-7220W



LMD-5320



LMD-4420

LMD-7220W Connector Panel

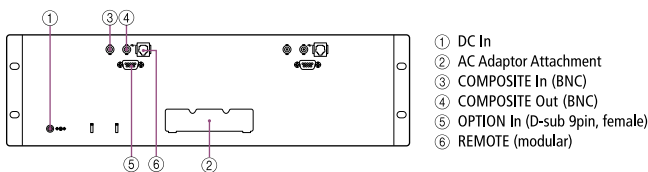

LMD-5320 Connector Panel

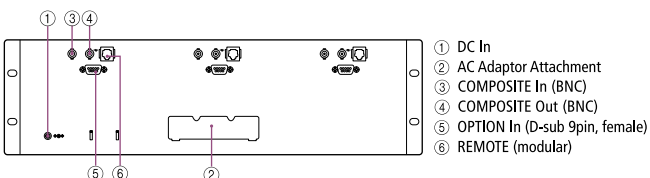

LMD-4420 Connector Panel

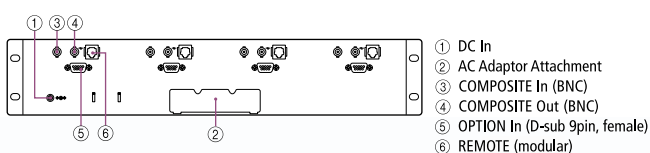

## Panel Types

	Panel Aspect Ratio	Number of Displays	Display Size* <sup>1</sup>
LMD-4420	4:3	4	4-inch
LMD-5320	4:3	3	5.6-inch
LMD-7220W	16:9* <sup>2</sup>	2	7-inch

\*<sup>1</sup> Viewable area measured diagonally.

\*<sup>2</sup> HD signals must be externally down-converted for display.

## Input Capability

All multi-display type LUMA monitors accept either composite or SDI signals. Each LCD panel is equipped with a composite connector as standard, while SDI input can be added simply by installing the optional BKM-320D\*.

\* One BKM-320D is required per screen.

## High Picture Quality

Although small in size, the multi-display type LUMA monitors incorporate high-grade LCD panels with high brightness and high contrast. These LCD panels also offer a wide viewing angle, both vertically and horizontally.

## Operational Convenience

### Selectable Aspect Ratio (LMD-7220W only)

The scan aspect ratio of the displays on the LMD-7220W can be switched between 16:9 and 4:3 by pressing a button on the front panel.

### Three-color Tally

The LMD-7220W, LMD-5320, and LMD-4420 come equipped with a tally lamp that can be lit up via a parallel remote connector. The status of the signal displayed on the monitor can be identified by the tally color – red, green, or amber.

### Parallel Remote Control

The multi-display type LUMA monitors can be controlled remotely via their parallel remote connector. There are 5 functions (LMD-7220W)/4 functions (LMD-5320/LMD-4420) in the remote menu (such as the ability to switch input signals), which can be allocated to the connector.

## Low Power Consumption

Compared to conventional CRT multiple monitors, multi-display type LUMA monitors offer drastic reductions in power consumption and room-cooling requirements. This is a huge bonus in applications where power consumption is critical, such as OB van installations.

## Slim and Light

Thanks to their thin and lightweight designs, the multi-display type LUMA monitors are ideal for installations where space is limited.

## Convenient Installation

All multi-display type LUMA monitors are mountable on a 19-inch EIA standard rack. For viewing convenience, the LMD-7220W and LMD-5320 offer a 5-step tilt mechanism, and the LMD-4420 offers a 3-step tilt mechanism.

# Optional Accessories



- **BKM-244CC**  
HD/SD-SDI Closed Caption Adaptor (for high-grade type)



- **BKM-243HS**  
HD-SDI/SD-SDI Input Adaptor (for high-grade type)



- **BKM-220D**  
SD-SDI 4:2:2 Input Adaptor (for high-grade type)



- **BKM-229X**  
Analog Component Adaptor (for high-grade type)



- **BKM-227W**  
NTSC/PAL Input Adaptor (for high-grade type)



- **BKM-320D**  
SD-SDI Input Adaptor (for LMD-2030W, LMD-1420, LMD-7220W, LMD-5320, and LMD-4420)

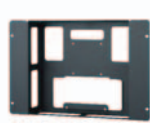

- **MB-526**  
Mounting Bracket (for LMD-1420 and LMD-1410)



- **MB-529**  
Mounting Bracket (for LMD-2050W and LMD-2030W)

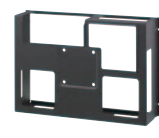

- **MB-530**  
Mounting Bracket (for LMD-1750W)



- **MB-525**  
Mounting Bracket (for handheld type)



- **MB-528**  
Mounting Panel (for handheld type)



- **VF-509**  
ENG Kit (Viewing Hood, Carrying Handle and Connector Protector) (for handheld type)



- **SU-561**  
Mounting Stand (for LMD-1750W)



- **BP-L80S**  
Lithium-ion Battery



- **BP-L60S**  
Lithium-ion Battery



- **BP-GL95/BP-GL65**  
Rechargeable Lithium-ion Battery Pack



- **BC-L70**  
Lithium-ion Battery Charger



- **BC-L500**  
Lithium-ion Battery Charger



- **BC-M150**  
Lithium-ion Battery Charger

# Feature Comparison

High-grade Type				
Model No.	LMD-4250W	LMD-2450W	LMD-2050W	LMD-1750W
PANEL Type	a-Si TFT Active Matrix			
Picture Size*	42-inch	24-inch	20-inch	17-inch
Picture Resolution	1920 x 1080 pixels	1920 x 1200 pixels	1680 x 1050 pixels	1280 x 768 pixels
Panel Aspect Ratio	16:9	16:10		15:9
Panel Bit Depth	8 bit			
INPUT/ OUTPUT CAPABILITY	HD (Digital/Analog)/SD (Digital/Analog)			
Acceptable Computer System	Full HD	up to WUXGA	up to WSXGA+	up to WXGA
<b>ANALOG VIDEO</b>				
Composite	BNC x 1 (IN), BNC x 1 (OUT**)			
Y/C	4-pin Mini-DIN x 1 (IN), 4-pin mini-DIN x 1 (OUT**)			
Component/RGB	BNC x 3 (IN), BNC x 3 (OUT**)			
HD-15	D-sub 15-pin x 1 (IN)			
External Sync	BNC x 1 (IN), BNC x 1 (OUT**)			
<b>DIGITAL INTERFACE</b>				
SD-SDI Input	BKM-220D, BKM-243HS			
HD-SDI Input	BKM-243HS			
SDI with Audio Decoding	Yes			
HDMI	No			
DVI-D	DVI-D x 1 (IN)			
Option Board	2 slots (BKM-244CC, BKM-243HS, BKM-220D, BKM-229X, BKM-227W)			
<b>Control</b>				
Parallel	Modular 8-pin x 1			
Serial	D-sub 9-pin (RS-232C) x 1, RJ-45 modular connector (LAN, 10BASE-T/100BASE-TX) x 1			
<b>Audio</b>				
Audio Input/Output	Phono Jack x 2 (IN), Phono Jack x 2 (OUT)			
Built-in Speaker Out	1.0 W + 1.0 W Stereo			
<b>Features</b>				
Signal Processing	10 bit			
Color Matching	ChromaTru			
Marker	Aspect, Center, Safety Area			
Color Temperature	9300k, 6500k, user			
Closed Caption	EIA608 COMPOSITE (standard), EIA708 (BKM-244CC)			
Aspect Switch	16:9, 4:3			
Scan	0%, 5%			
Blue Only	Yes			
H/V Delay	Yes			
Tally	No			3-Color
Smart APA	Yes			
EIA 19-inch Rack Mounting	Not Applicable		MB-529	MB-530
VESA Mounting	400 x 400 mm	100 x 100 mm		100 x 100 mm, 75 x 75 mm
Desk-top Stand	No	Supplied		No
Li-ion Battery Operation	No			
DC Operation	No	24 V		12 V
Application	<span style="background-color: #90EE90; border: 1px solid black; padding: 2px;">MED</span> <span style="background-color: #FFD700; border: 1px solid black; padding: 2px;">EDU</span> <span style="background-color: #808080; border: 1px solid black; padding: 2px;">COR</span> <span style="background-color: #66B3FF; border: 1px solid black; padding: 2px;">CC</span> <span style="background-color: #90EE90; border: 1px solid black; padding: 2px;">GOV</span> <span style="background-color: #FF69B4; border: 1px solid black; padding: 2px;">ENT</span>			

\* Viewable area, measured diagonally.

\*\* Loop-Through, Automatic Termination.









Multi-display Type			
Model No.	LMD-7220W	LMD-5320	LMD-4420
PANEL Type	a-Si TFT Active Matrix		
Picture Size*	7-inch x 2	5.6-inch x 3	4-inch x 4
Picture Resolution	480 x 234 pixels	320 x 234 pixels	480 x 234 pixels
Panel Aspect Ratio	16:9	4:3	
INPUT/ OUTPUT CAPABILITY	HD (Analog)/SD (Digital/Analog)		
Acceptable Computer System	No		
<b>ANALOG VIDEO</b>			
Composite	{ BNC x 1 (OUT**) } x 2 monitors	{ BNC x 1 (OUT**) } x 3 monitors	{ BNC x 1 (OUT**) } x 4 monitors
<b>DIGITAL INTERFACE</b>			
SD-SDI Input	BKM-320D x 2	BKM-320D x 3	BKM-320D x 4
Option Board	{ D-sub 9-pin x 1, (BKM-320D IN) } x 2 monitors	{ D-sub 9-pin x 1, (BKM-320D IN) } x 3 monitors	{ D-sub 9-pin x 1, (BKM-320D IN) } x 4 monitors
<b>Control</b>			
Parallel	{ Modular 8-pin x 1 } x 2 monitors	{ Modular 8-pin x 1 } x 3 monitors	{ Modular 8-pin x 1 } x 4 monitors
<b>Features</b>			
Tally	3-Color		
EIA 19-inch Rack Mounting	MB-525, MB-528		
Desk-top Stand	Supplied		
Li-ion Battery Operation	No		
DC Operation	Yes		
Application	<span style="background-color: #FFD700; border: 1px solid black; padding: 2px;">EDU</span> <span style="background-color: #808080; border: 1px solid black; padding: 2px;">COR</span> <span style="background-color: #66B3FF; border: 1px solid black; padding: 2px;">CC</span> <span style="background-color: #90EE90; border: 1px solid black; padding: 2px;">GOV</span> <span style="background-color: #808080; border: 1px solid black; padding: 2px;">SEC</span> <span style="background-color: #FF8C00; border: 1px solid black; padding: 2px;">CON</span>		

\* Viewable area, measured diagonally.

\*\* Loop-Through, Automatic Termination.





Application Icons

<span style="background-color: #90EE90; border: 1px solid black; padding: 2px;">MED</span> Medical	<span style="background-color: #FFD700; border: 1px solid black; padding: 2px;">EDU</span> Education	<span style="background-color: #808080; border: 1px solid black; padding: 2px;">COR</span> Corporate	<span style="background-color: #66B3FF; border: 1px solid black; padding: 2px;">CC</span> Content Creation	<span style="background-color: #90EE90; border: 1px solid black; padding: 2px;">GOV</span> Government
<span style="background-color: #808080; border: 1px solid black; padding: 2px;">SEC</span> Security	<span style="background-color: #FF69B4; border: 1px solid black; padding: 2px;">ENT</span> Entertainment	<span style="background-color: #FF8C00; border: 1px solid black; padding: 2px;">SYS</span> System Integrator	<span style="background-color: #66B3FF; border: 1px solid black; padding: 2px;">FAC</span> Factory	

Entry-level Type			
Model No.	LMD-2030W	LMD-1420	LMD-1410
PANEL Type	a-Si TFT Active Matrix		
Picture Size*	20-inch	14-inch	
Picture Resolution	1680 x 1050 pixels	640 x 480 pixels	
Panel Aspect Ratio	16:10	4:3	
Panel Bit Depth	8 bit		
INPUT/OUTPUT CAPABILITY	HD (Digital/Analog)/ SD (Digital/Analog)	HD (Analog)/ SD (Digital/Analog)	HD (Analog)/ SD (Analog)
Acceptable Computer System	No		
<b>ANALOG VIDEO</b>			
Composite	BNC x 1 (IN), BNC x 1 (OUT**)	BNC x 2 (IN), BNC x 2 (OUT**)	
Y/C	4-pin Mini-DIN x 1 (IN), 4-pin mini-DIN x 1 (OUT**)		
Component/RGB	BNC x 3 (IN), BNC x 3 (OUT**), RCA Phono Jack x 1 (IN), RCA Phono Jack x 1 (OUT**)		
HD-15	No		
External Sync	BNC x 1 (IN), BNC x 1 (OUT**)	No	
<b>DIGITAL INTERFACE</b>			
SD-SDI Input	BKM-320D, RCA Phono Jack x 1 (IN) No	No	
HD-SDI Input	No		
SDI with Audio Decoding	No		
HDMI	Yes	No	
DVI-D	No		
Option Board	D-sub 9-pin x 1, (BKM-320D IN)		
<b>Control</b>			
Parallel	Modular 8-pin x 1		
<b>Audio</b>			
Audio Input/Output	RCA Phono Jack x 1 (IN), RCA Phono Jack x 1 (OUT**)	RCA Phono Jack x 2 (IN), RCA Phono Jack x 2 (OUT)	
Built-in Speaker Out	0.5 W Mono		
<b>Features</b>			
Signal Processing	8 bit		
Marker	Aspect, Center	Aspect, Center, Safety Area	No
Color Temperature	High, Low, User		
Aspect Switch	16:9, 4:3		
Scan	-3%, 5%		
Blue Only	Yes	No	
H/V Delay	No		
Tally	3-Color	No	
EIA 19-inch Rack Mounting	MB-529	MB-526	
VESA Mounting	100 x 100 mm		
Desk-top Stand	Supplied		
Li-ion Battery Operation	No		
DC Operation	No		
Application	        		

\* Viewable area, measured diagonally.

\*\* Loop-Through, Automatic Termination.

Handheld Type			
Model No.	LMD-9050	LMD-9030	LMD-9020
PANEL Type	a-Si TFT Active Matrix		
Picture Size*	8.4-inch		
Picture Resolution	1024 x 768 pixels	640 x 480 pixels	
Panel Aspect Ratio	4:3		
INPUT/OUTPUT CAPABILITY	HD (Digital/Analog)/ SD (Digital/Analog)	HD (Analog)/ SD (Digital/Analog)	HD (Analog)/ SD (Analog)
Acceptable Computer System	No		
<b>ANALOG VIDEO</b>			
Composite	BNC x 2 (IN), BNC x 2 (OUT)		
Y/C	4-pin Mini-DIN x 1 (IN), 4-pin mini-DIN x 1 (OUT)		
Component/RGB	BNC x 3 (IN), Mini Jack x 1 (IN)		
HD-15	No		
External Sync	BNC x 1 (IN)		
<b>DIGITAL INTERFACE</b>			
SD-SDI Input	BNC x 2 (IN) BNC x 1 (OUT)	BNC x 2 (IN) BNC x 1 (OUT)	No
HD-SDI Input	Automatic Detection	No	
SDI with Audio Decoding	Yes	No	
<b>Control</b>			
Parallel	Modular 8-pin x 1		
<b>Audio</b>			
Audio Input/Output	Mini Jack x 2 (IN), Mini Jack x 1 (OUT)		
Built-in Speaker Out	0.5 W Mono		
<b>Features</b>			
Marker	Aspect, Center		
Color Temperature	High, Low, User		
Aspect Switch	16:9, 4:3		
Scan	-3%, 0%, 5%		
Blue Only	Yes		
Tally	3-Color		
EIA 19-inch Rack Mounting	MB-525, MB-528		
Desk-top Stand	Supplied		
Li-ion Battery Operation	Yes		
DC Operation	Yes		
Application	    		

\* Viewable area, measured diagonally.

# Specifications

High-grade  
Type



## Picture Performance

Type	A-Si TFT Active Matrix LCD	A-Si TFT Active Matrix LCD
Resolution	1920 x 1080 pixels (Full HD)	1920 x 1200 pixels (WUXGA)
Picture Size (H x W) (Viewable area) (Diagonal)	Approx. Approx. 36 5/8 x 20 5/8 inches (930 x 523 mm) Approx. Approx. 42 inches (1067 mm)	Approx. Approx. 20 1/2 x 12 1/8 inches (518.4 x 324.0 mm) Approx. 24.1 inches (613.2 mm)
Aspect	16:9	16:10
Colors	Approx 16,770,000 colors (8bits)	Approx 16,700,000 colors (8bits)
Viewing Angle	88°/88°/88°/88° (typical) (up/down/left/right contrast>10:1)	89°/89°/89°/89° (typical) (up/down/left/right contrast>10:1)

## Input

Standard Composite	BNC x 1, 1.0 Vp-p ±3dB sync negative	
Y/C	4pin Mini DIN x 1 Y: 1.0 Vp-p ±3dB sync negative, C: 0.286 Vp-p ±3dB (NTSC burst signal level), 0.3 Vp-p ±3dB (PAL burst signal level)	
RGB, Component	BNC x 3 RGB : 0.7 Vp-p ±3dB (Sync On Green, 0.3 Vp-p sync negative) Component : 0.7 Vp-p ±3dB (75% chrominance standard color bar signal)	
External Sync	BNC x 1 0.3 to 4.0 Vp-p ±bipolarity ternary or negative polarity binary	
Audio	RCA phono jack x 2 (L, R) -5 dBu 47 k Ω or higher	
HD15	D-sub 15 pin x 1, R/G/B: 0.7 Vp-p sync positive (Sync On Green, 0.3 Vp-p sync negative) Sync : Total level (polarity free, H/V separate and composite sync) Plug & Play function : corresponds to DDC-2B	
DVI	TMDs signal link w/HDCP (fv:50.0 to 85.1 Hz, fh:31.5 to 77.0 kHz, Dot Clock:25.175 – 142.00 MHz)	TMDs signal link (fv:50.0 to 85.1 Hz, fh:31.5 to 77.0 kHz, Dot Clock:25.175 – 162.000 MHz)
Parallel remote	Modular connector 8 pin x 1 (pin assignment at users' allocation)	
Serial remote (LAN)	D-sub 9-pin (RS232C) x 1, RJ-45 modular connector (ETHERNET) x 1 (10BASE-T/100BASE-TX)	
DC in	—	XLR type 4pin x 1 DC24V (output impedance 0.005 Ω or less)
Optional Option input slot	2 slots (for HD-SDI, SDI capability and extra analog I/O's)	

## Output

Standard Composite	BNC x 1, Loop-through, with 75 Ω automatic termination	
Y/C	4pin mini DIN x 1 Loop-through, with 75 Ω automatic termination	
RGB, Component	BNC x 3, Loop-through, with with 75 Ω automatic termination	
External Sync	BNC x 1, Loop-through, with 75 Ω automatic termination	
Audio monitor out	RCA phono jack type x 2 (L, R)	
Speaker (Built-in)	1.0 W + 1.0 W (stereo)	

## General

Power Requirement	AC100 V to 240 V 50/60 Hz 2.3 A to 1.1 A	AC100 V to 240 V 50/60 Hz 0.6 A to 1.1 A, DC2 4V 4.6 A
Power Consumption	Maximum Approx. 230 W (with 2 x BKM-229X)	Maximum Approx. 115 W (with 2 x BKM-229X)
Operating Temperature	0 to 35 °C (recommended operation temperature 20 to 30 °C)	
Operating Humidity	30 to 85% (No condensation)	
Storage & Transport Temperature	-20 to 60 °C	
Storage & Transport Humidity	0 to 90 %	
Operating/Storage/Trans. Pressure	700 to 1060 hPa	
Dimensions (W x H x D)		
Dimension	40 1/2 x 24 3/8 x 5 1/8 inch (1027 x 616 x 130 mm)	23 3/4 x 19 5/8 x 10 3/4 inch (602.4 x 497.9 x 269.9 mm)
Dimension without stand	—	23 3/4 x 15 1/4 x 4 3/8 inch (602.4 x 386.2 x 110.0 mm)
Display Stand (W x H x D)	—	12 5/8 x 14 1/4 x 10 3/4 inches (320.0 x 361.5 x 269.9 mm)
Weight	Approx. 55 lb 2 oz (25 kg) with BKM-229X x 2	Approx. 25 lb 2 oz (11.4 kg) with BKM-229X x 2
Without option boards	Approx. 54 lb (24.5 kg)	Approx. 24 lb 4 oz (11.0 kg)
Supplied Accessories	AC power cord, AC plug holder, Operating Instructions, CD-ROM, Warranty Card, Using the CD-ROM Manual	

## Dimensions

LMD-4250W

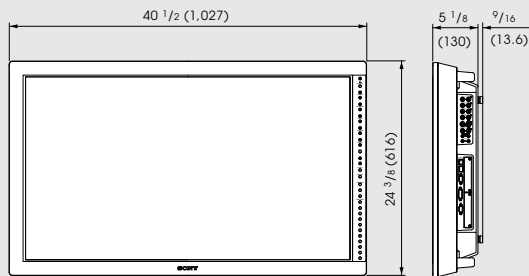

LMD-2450W

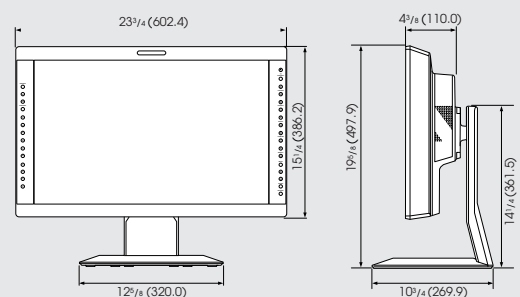

Unit: inches (mm)



LMD-2050W



LMD-1750W

Picture Performance		A-Si TFT Active Matrix LCD	
Type	A-Si TFT Active Matrix LCD		
Resolution	1680 x 1050 pixels (WSXGA+)	1280 x 768 pixels	
Picture Size (H x W) (Viewable area) (Diagonal)	Approx. 17 1/8 x 10 3/4 inches (433.5 x 272.9 mm) Approx. 20 1/8 inches (511.1 mm)	Approx. 14 5/8 x 8 3/4 inches (Approx. 370 x 222 mm) Approx. 17 inches (Approx. 431 mm)	
Aspect	16:10		
Colors	Approx 16,700,000 colors (8bits)		
Viewing Angle	89°/89°/89°/89° (typical) (up/down/left/right contrast>10:1)		85°/85°/85°/85° (typical) (up/down/left/right contrast>10:1)
Input			
Standard	Composite BNC x 1, 1.0 Vp-p ±3dB sync negative		
Y/C	4pin Mini DIN x 1 Y: 1.0 Vp-p ±3dB sync negative, C: 0.286 Vp-p ±3dB (NTSC burst signal level), 0.3 Vp-p ±3dB (PAL burst signal level)		
RGB, Component	BNC x 3 RGB : 0.7 Vp-p ±3dB (Sync On Green, 0.3 Vp-p sync negative) Component : 0.7 Vp-p ±3dB (75% chrominance standard color bar signal)		
External Sync	BNC x 1 0.3 to 4.0 Vp-p ±bipolarity ternary or negative polarity binary		
Audio	RCA phono jack x 2 (L, R) -5 dBu 47 k Ω or higher		
HD15	D-sub 15 pin x 1, R/G/B: 0.7 Vp-p sync positive (Sync On Green, 0.3 Vp-p sync negative) Sync : Total level (polarity free, H/V separate and composite sync) Plug & Play function : corresponds to DDC-2B		
DVI	TMDS signal link (fv:50.0 to 85.1 Hz, fh:31.5 to 77.0 kHz, Dot Clock:25.175 – 108.000 MHz)	TMDS signal link w/HDCP (fv:50.0 to 85.1 Hz, fh:31.5 to 77.0 kHz, Dot Clock:25.175 – 141.00 MHz)	
Parallel remote	Modular connector 8 pin x 1 (pin assignment at users' allocation)		
Serial remote (LAN)	D-sub 9-pin (RS232C) x 1, RJ-45 modular connector (ETHERNET) x 1 (10BASE-T/100BASE-TX)		
DC in	XLR type 4pin x 1 DC24V (output impedance 0.005 Ω or less)		
Optional	Option input slot 2 slots (for HD-SDI), SDI capability and extra analog I/O's		
Output			
Standard	Composite BNC x 1, Loop-though, with 75 Ω automatic termination		
Y/C	4pin mini DIN x 1 Loop-though, with 75 Ω automatic termination		
RGB, Component	BNC x 3, Loop-though, with with 75 Ω automatic termination		
External Sync	BNC x 1, Loop-though, with 75 Ω automatic termination		
Audio monitor out	RCA phono jack x 2 (L, R)		
Speaker (Built-in)	1 W + 1 W (stereo)		
General			
Power Requirement	AC100 V to 240 V 50/60 Hz 0.4 A to 0.8 A, DC24 V 3.3A		AC100 V to 240 V 50/60 Hz 0.7 A to 0.3 A, DC 12 V, 5.7 A
Power Consumption	Maximum Approx. 95 W (with 2 x BKM-229X)		Maximum Approx. 70 W (with 2 x BKM-229X)
Operating Temperature	0 to 35 °C (recommended operation temperature 20 to 30 °C)		
Operating Humidity	30 to 85% (No condensation)		
Storage & Transport Temperature	-20 to 60 °C		
Storage & Transport Humidity	0 to 90 %		
Operating/Storage/Trans. Pressure	700 to 1060 hPa		
Dimensions (W x H x D)			
Dimension	20 1/2 x 18 1/2 x 10 3/4 inch (518.5 x 468.4 x 269.9 mm)	Approx. 17 3/8 x 11 1/4 x 4 1/4 inch (439.5 x 284 x 105 mm)	
Dimension without stand	20 1/2 x 13 x 4 1/8 inch (518.5 x 328.7 x 104.7 mm)	—	
Display Stand (W x H x D)	12 5/8 x 14 1/4 x 10 3/4 inches (320.0 x 361.5 x 269.9 mm)		
Weight	With two option boards Approx. 10.5 kg ( 23 lb 2 oz) with BKM-229X x 2		Approx. 14 lb 2 oz (6.4 kg) with BKM-229X x 2
Without option boards	Approx. 22 lb 4 oz (10.1 kg)		Approx. 13 lb 4 oz (6 kg)
Supplied Accessories	AC power cord, AC plug holder, Operating Instructions, CD-ROM, Warranty Card, Using the CD-ROM Manual		

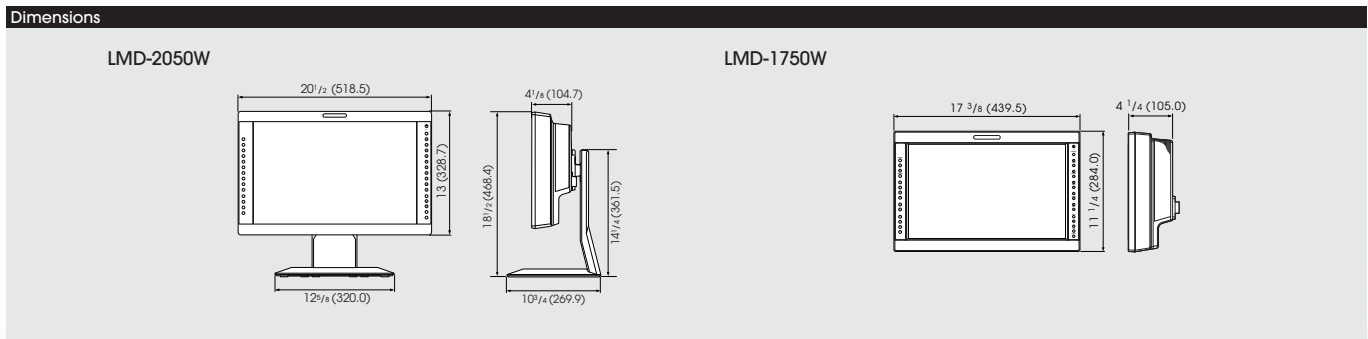

Unit: inches (mm)

# Specifications

## Entry-level Type



Picture Performance			
Type	A-Si TFT Active Matrix LCD		A-Si TFT Active Matrix LCD with a multi-layer AR-coated protection panel
Resolution	1680 x 1050 pixels (WSXGA+)		640 x 480 pixels (VGA)
Picture Size (H x W) (Viewable area) (Diagonal)	Approx. 17 1/8 x 10 3/4 inches (Approx. 433 x 271 mm) Approx. 20.1-inch (511 mm)		Approx. 11 1/4 x 8 3/8 inches (Approx. 283 x 212 mm) Approx. 354 mm (14-inch)
Aspect	16:10		4:3
Colors	Approx. 16,700,000		Approx. 16,200,000 colors
Viewing Angle	89°/89°/89°/89° (typical) (up/down/left/right contrast>10:1)		85°/85°/85°/85° (typical) (up/down/left/right contrast>10:1)
Input			
Line A	Composite	BNC x 1, 1.0 Vp-p ±3dB, sync 0.3 Vp-p negative	
	Y/C	4-pin mini-DIN x 1 Y: 1.0Vp-p ±3 dB C: 0.286 Vp-p ±3 dB (NTSC), 0.3 Vp-p ±3 dB (PAL), sync 0.3 Vp-p negative	
	Audio in	RCA phono jack x 1, -5 dBu 47 Ω or higher	
Line B	Composite	BNC x 1, 1.0 Vp-p ±3dB, sync 0.3 Vp-p negative	
	Audio in	RCA phono jack x 1, -5 dBu 47 Ω or higher	
RGB/Component		BNC x 3, 0.7 Vp-p ±3 dB (Sync on Green 0.3 Vp-p, negative: RGB) (75% chrominance standard color bar signal: Component)	
	Audio in	RCA phono jack x 1, -5 dBu 47 kΩ or higher	
Option	D1-SDI	D-sub 9-pin x 1	
	Audio in	AUDIO input (RCA phono jack x1), -5 dBu 47 kΩ or higher	
External Sync		BNC x1, 0.3 to 4 Vp-p negative polarity binary	
HDMI input		HDMI x 1	-
Remote	Parallel remote	Modular connector 8-pin x1	
Output			
Line A	Composite	BNC x 1, Loop-through, with 75 Ω automatic termination	
	Y/C	DIN 4 pin x 1, Loop-through, with 75 Ω automatic termination	
	Audio out	RCA phono jack x1, Loop-through	
Line B	Composite	BNC x 1, Loop-through, with 75 Ω automatic termination	
	Audio out	RCA phono jack x 1, Loop-through	
RGB/Component		BNC x3, Loop-through, with 75 Ω automatic termination	
	Audio out	RCA phono jack x 1, Loop-through	
External Sync		BNC x1, Loop-through, with 75 Ω automatic terminal function	
Built-in speaker output		0.5 W (mono)	
General			
Power Consumption	Approx. 72 W		Approx. 51 W
Power requirement	AC100 to 240V, 50/60 Hz		
Operating Temperature	0 to 35 °C (recommended operation temperature 20 to 30 °C)		
Operating Humidity	30 to 85% (No condensation)		
Storage & Transport Temperature	-20 to 60 °C		
Storage & Transport Humidity	0 to 90 %		
Operating/Storage/Trans. Pressure	700 to 1060 hPa		
Dimensions (W x H x D)			
	Dimension	Approx. 19 1/2 x 16 1/8 x 10 1/2 inch (493 x 408 x 264 mm)	Approx. 13 5/8 x 14 x 10 1/2 inch (343 x 354 x 264 mm)
	Dimension without stand	Approx. 19 1/2 x 14 1/4 x 3 1/2 inch (493 x 361 x 87mm)	Approx. 13 5/8 x 12 x 3 1/2 inch (343 x 304 x 87mm)
Weight	Panel & Stand	Approx. 212 lb 3 oz (9.6 kg)	Approx. 14 lb 16 oz (6.8 kg)
	Panel only	Approx. 17 lb 6 oz (7.9 kg)	Approx. 11 lb 4 oz (5.1 kg)
Supplied Accessories	Display Stand, AC power cord, AC plug holder, Operating Instructions, CD-ROM, Using the CD-ROM Manual, Warranty Card		

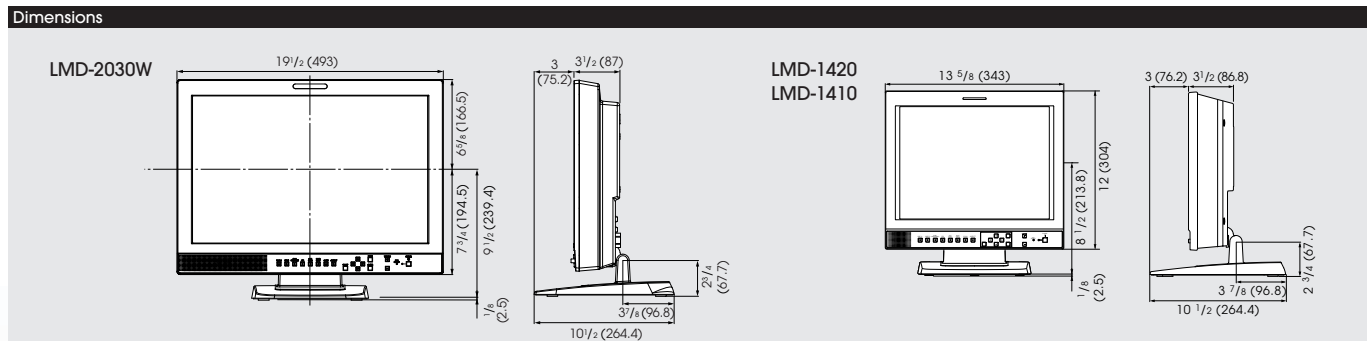

Unit: inches (mm)

# Handheld Type



LMD-9050



LMD-9030



LMD-9020

Picture Performance			
Type	a-Si TFT Active Matrix LCD with a multi-layer AR-coated protection panel		
Resolution	1024 x 768 pixels	640 x 480 pixels	
Picture Size (H x W), (Viewable area) (Diagonal)	Approx. 6 3/4 x 5 1/8 inches, (Approx. 170.5 x 127.9 mm) Approx. 8.4-inch (213 mm)	Approx. 6 3/4 x 5 1/8 inches, (Approx. 170.9 x 128.2 mm) Approx. 8.4-inch (213.6 mm)	
Aspect	4:3		
Colors	16,770,000 colors		
Viewing Angle	85°/85°/85°/85° (typical) (up/down/left/right contrast>10:1)		
Input			
Line A	Composite	BNC x 1, 1.0 Vp-p +3dB, -6 dB sync negative	
	Y/C	4-pin mini-DIN x 1 Y : 1.0 Vp-p + 3dB, -6 dB sync negative C : 0.286 Vp-p ±3 dB (NTSC), 0.3 Vp-p ±3 dB (PAL)	
	Audio	Mini jack x 1, -5 dBu 47 kΩ or higher	
Line B	Composite	BNC x 1, 1.0 Vp-p +3 dB, -6 dB sync negative	
	Audio	Mini jack x 1, -5 dBu 47 kΩ or higher	
RGB/Component	RGB/Component	BNC x 3, 0.7 Vp-p ±3 dB (Sync on Green 0.3 Vp-p, negative: RGB) (75% chrominance standard color bar signal: Component)	
	Audio	Mini jack x 1, -5 dBu 47 kΩ or higher	
Ext.sync	BNC x 1, 0.3 to 4 Vp-p ± bipolarity ternary or negative polarity binary		
SDI	HD-SDI/D1-SDI: BNC x 2 (HD and D1 are automatically detected) Sampling frequency D1-SDI:Y/R-Y/B-Y 13.5 MHz, HD-SDI:Y/PB/PR 74.25 MHz Quantization 10 bits/sample	D1-SDI: BNC x 2, Sampling frequency :Y/R-Y/B-Y 13.5 MHz, Quantization 10 bits/sample	—
Remote	Parallel remote	Modular connector 8-pin x 1(Assignable)	
Output			
Line A	Composite	BNC x 1, Loop-through, with 75 Ω automatic termination	
	Y/C	4-pin mini-DIN x 1, Loop-through, with 75 Ω automatic termination	
Line B	Composite	BNC x 1, Loop-through, with 75 Ω automatic termination	
Monitor output	HD-SDI/D1-SDI:	BNC x 1, Output signal : amplitude 800 mVp-p ±10%, Output impedance : 75 Ω unbalanced	D1-SDI: BNC x 1, Output signal amplitude : 800 mVp-p ±10%, Output impedance : 75 Ω unbalanced
	Audio output	Mini jack x 1, Loop-through	
Headphones output	Mini jack x 1(Monaural), Loop-through		
Speaker output	0.5 W (Monaural)		
General			
Power Consumption	Monitor : Approx. 24 W, With AC Adaptor : Approx. 28 W	Approx. 16 W, With AC Adaptor : Approx. 22 W	Approx. 15 W, With AC Adaptor : Approx. 20 W
Power requirement	AC 100 to 240 V, 50/60 Hz, 0.82 A, DC 12 V 2.2 A, Rechargeable Battery Pack	AC 100 to 240 V, 50/60 Hz, 0.82 to 0.42 A, DC 12 V 1.6 A, Rechargeable Battery Pack	AC 100 to 240 V, 50/60 Hz, 0.82 to 0.42 A, DC 12 V 1.5 A, Rechargeable Battery Pack
Operating Temperature	0 to 40 °C		
Operating Humidity	30 to 85 % (No condensation)		
Operating/Storage/Trans. Pressure	700 to 1060 hPa		
Storage & Transport Temperature	-20 to 60 °C		
Storage & Transport Humidity	0 to 90 %		
Dimensions (W x H x D)	Approx. 8 5/8 x 8 1/8 x 5 3/8 inches (216 x 206 x 136.1 mm)		
	Approx. 8 5/8 x 9 1/8 x 6 3/8 inches (216 x 230 x 159.5 mm)		
	Approx. 8 5/8 x 9 1/8 x 8 3/8 inches (216 x 230 x 210 mm)		
Weight	Approx. 6 lb 10 oz (3.0 Kg)		
	Approx. 7 lb 1 oz (3.2 Kg)		
	Approx. 8 lb 10 oz (3.9 Kg)		
Supplied Accessories	AC adaptor (1), AC Cord (1), AC plug holder (1), Operating instructions (1), CD-ROM (1), Warranty card (1), Using the CD-ROM Manual (1)		

## Handheld Type

LMD-9050  
LMD-9030  
LMD-9020

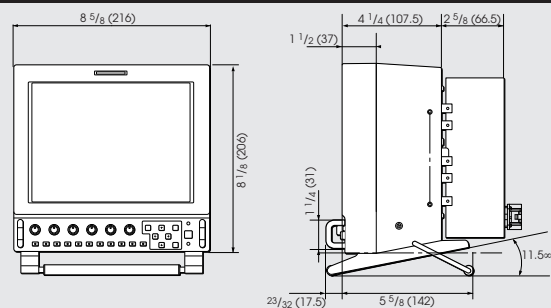

Unit: inches (mm)

# Specifications

## Multi-display Type



Picture Performance			
Type	a-Si TFT Active Matrix		
Resolution	480 x 234 pixels	320 x 234 pixels	480 x 234 pixels
Picture Size (H x W) (Viewable area) (Diagonal)	Approx. 6 1/8 x 3 1/2 inches (Approx. 154.1 x 86.6 mm) Approx. 7 inches (176.7 mm)	Approx. 4 1/2 x 3 3/8 inches (Approx. 113.3 x 84.7 mm) Approx. 5 5/8 inches (141.5 mm)	Approx. 3 1/4 x 2 1/2 inches (Approx. 82.1 x 61.8 mm) Approx. 4 1/8 inches (102.8 mm)
Aspect	16:9		4:3
Colors	Full color		
Viewing Angle	40°/65°/65°/65° (typical) (up/down/left/right contrast>10:1)	50°/30°/50°/50° (typical) (up/down/left/right contrast>10:1)	
Input/Output			
Composite			
Input	BNC (x 2), 1.0 Vp-p ±2 dB, sync negative	BNC (x 3), 1.0 Vp-p ±2 dB, sync negative	BNC (x 4), 1.0 Vp-p ±2 dB, sync negative
Output	BNC (x2), Loop through, Automatic 75 Ω termination	BNC (x 3), Loop through, Automatic 75 Ω termination	BNC (x 4), Loop through, Automatic 75 Ω termination
OPTION IN	D-sub 9pin (x2)	D-sub 9pin (x3)	D-sub 9pin (x4)
Remote			
Parallel	Modular 8 pin (x2)	Modular 8 pin (x3)	Modular 8 pin (x4)
General			
Power Consumption	Maximum: Approx. 26 W (with 2 x BKM-320D) Standard: Approx. 23 W (without optional input adaptor)	Maximum: Approx. 28 W (with 3 x BKM-320D) Standard: Approx. 22 W (without optional input adaptor)	Maximum: Approx. 26 W (with 4 x BKM-320D) Standard: Approx. 18 W (without optional input adaptor)
Power requirement	12V DC (with the supplied AC power adaptor), AC power adaptor:AC 100 to 240 V, 50/60 Hz		
Peak inrush current	(1) Power on, current probe method:57A (230V) (2) Hot switching inrush current, measured in accordance with European standard EN55103-1:8A (230V)	(1) Power on, current probe method:55A (230V)	(1) Power on, current probe method:53A (230V)
Operating Temperature	32 to 95°F (0 to 35°C)		
Operating Humidity	30 to 85 % (no condensation)		
Storage & Transport Temperature	14 to 104°F (-10 to 40°C)		
Storage & Transport Humidity	0 to 90 %		
Operating / Storage / Trans. Pressure	700 hPa to 1060 hPa		
Dimensions (W x H x D)	19 x 5 1/4 x 1 7/8 inches (482 x 133 x 47 mm)*	19 x 5 1/4 x 1 7/8 inches (482 x 133 x 47 mm)*	19 x 3 1/2 x 1 7/8 inches (482 x 88.1 x 47 mm)*
Dimension including AC adaptor and BKM-320D	19 x 5 1/4 x 4 5/8 inches (482 x 133 x 116 mm)	19 x 5 1/4 x 4 5/8 inches (482 x 133 x 116 mm)	19 x 3 1/2 x 4 5/8 inches (482 x 88.1 x 116 mm)
Weight	Approx. 5 lb 1 oz (Approx. 2.3Kg)**	Approx. Approx. 5 lb 1 oz (2.3Kg)**	Approx. Approx. 4 lb 3 oz (1.9Kg)**
Supplied Accessories	AC power adaptor (1), AC Power Cord (1), AC plug holder (1), Screws for AC adaptor holder (2), Operating Instructions (1), Warranty Card (1)		

\* without the projection parts \*\* Excluding supplied accessories.

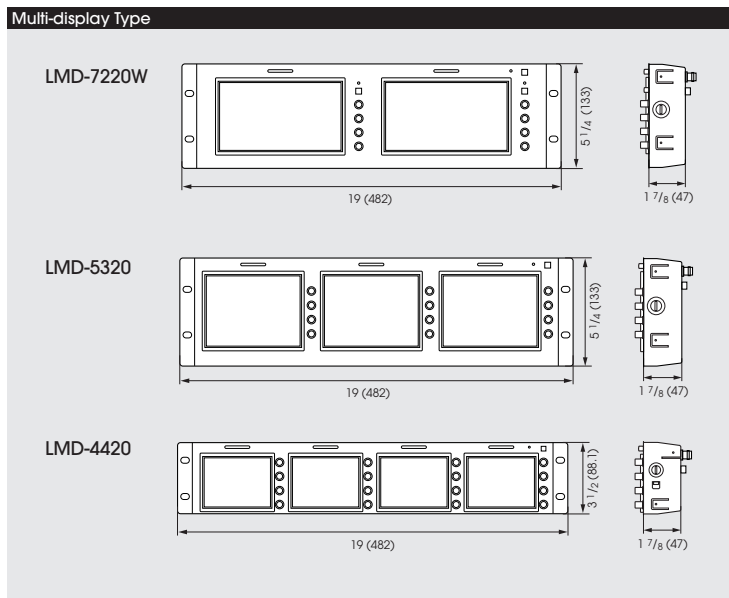

Unit: inches (mm)



**SONY**<sup>®</sup>

Sony Electronics Inc.  
1 Sony Drive  
Park Ridge, NJ 07656  
[sony.com/luma](http://sony.com/luma)

DI-0153 (MK10470V1)

©2008 Sony Electronics Inc. All rights reserved.  
Reproduction in whole or in part without permission is prohibited.  
Features and specifications are subject to change without notice.  
Images on monitors are simulated.  
Sony, ChromaTRU and LUMA are trademarks of Sony Electronics.  
VESA is a trademark of the Video Electronics Standard Association.

Printed in USA (3/08)