

SENTECH

STC-CL33A
STC-CLC33A
Product Specification

Small Cubic Type – VGA CCD
Color / Monochrome Camera Link Camera

Contents

I. Specifications	
A. Electronic Specs / Mechanical Specs / Environmental Conditions.....	1
B. Connector Specifications.....	2
1. Camera Link Connector.....	2
2. Interface Connector.....	2
3. Pin Assignments.....	2
II. Dimensions	
A. Dimensions.....	3
B. Dimensions (Tripod).....	4
C. Dimensions (Camera with Tripod).....	5

I. Specifications

A. Electronic Specifications / Mechanical Specifications / Environmental Conditions

Product		STC-CLC33A	STC-CL33A	
Electronic specifications	Imager	1/3" interline VGA color progressive CCD: ICX424AQ	1/3" interline VGA monochrome progressive CCD: ICX424AL	
	Total picture elements	692 (H) x 504 (V)		
	Effective picture elements	659 (H) x 494 (V)		
	Effective picture elements	VGA: 648 (H) x 494 (V)		
	Chip size	5.79 (H) x 4.89 (V) mm		
	Cell size	7.4 (H) x 7.4 (V) μ m		
	Scanning system	Progressive		
	Scanning method	Full scanning, Partial full scanning, 1/2 partial scanning, 1/4 partial scanning, Variable partial scanning	Full scanning, Partial full scanning, 1/2 partial scanning, 1/4 partial scanning, Variable partial scanning, Binning, Binning partial scanning, Binning 1/2 partial scanning, Binning 1/4 partial scanning, Binning variable partial scanning	
	Vertical frequency (Frame rate)	31.47 (30fps) / 62.94 (60fps) / 94.784 (90fps) Hz		
	Horizontal frequency	15.7343 (30fps) / 31.4685 (60fps) / 47.2028 (90fps) kHz		
	Pixel frequency	12.2727 (30fps) / 24.5454 (60fps) / 36.8181 (90fps) MHz		
	S/N ratio (standard deviation)	<= 10 Digit (Gain 0 dB)		
	Minimum scene illumination	2 Lux at F1.4	1 Lux at F1.4	
	Sync. System	Internal / External		
	Video output	Digital 8 or 10 bit Camera Link (Base configuration)		
	Tap	1 Tap		
	Shutter speed	OFF, 1/2 to 1/100,000 sec. (Variable at every H and clock)		
	Gain	0 to 27 dB		
	Gamma	1.0		
	Power supply	Input voltage	DC12V \pm 10%	
Consumption		Less than 1.8 W		
Trigger mode	Edge preset trigger (V-reset, Non-reset) Pulse width trigger (V-reset, Non-reset)			
Communication	RS232 via Camera Link connector			
Mechanical specifications	Dimensions	28 (W) x 28 (H) x 46.5 (D) mm including lens mount and the connector		
	Optical filter	No IR cut filter		
	Optical center accuracy	Positional accuracy in H and V directions: +/- 0.31 mm Rotational accuracy of H and V: +/- 2.1 deg.		
	Material	Case	Front, base and rear: Aluminum die cast (ADC12) Cover: Steel sheet covered with zinc	
		Tripod	Polycarbonate ABS	
	Lens mount	C mount		
	Interface connector	HR10A-7R-6PB (Hirose) or equivalent		
	Tripod	Tripod can be attached to 4 plates (4 screws on the bottom plate, 3 screws on the other 3 plates)		
Weight	Approximately 52 g (Camera: 43 g, tripod: 9 g)			
Environmental conditions	Temperature and humidity	Operational	Temperature: -5 to 50 deg. C, RH: 0 to 85% (No condensation)	
		Storage	Temperature: -30 to 65 deg. C, RH: 0 to 90% (No condensation)	
	Vibration	20Hz to 200Hz to 20Hz (5min./cycle), acceleration 10G, 3 directions 30 min. each		
	Shock	Acceleration 70G, half amplitude 6ms, 3 directions 3times each		
	Standard compliancy	EMS: EN61000-6-2, EMI: EN55011 (Class B)		
RoHS	RoHS compliance			

B. Connector Specifications

1. Camera Link Connector: SCR (3M) or equivalent

Caution: This product is not PoCL type. Only apply 12V power through the interface connector.

2. Interface Connector: HR10A-7R-6PB (Hirose) or equivalent
This connector is for a 12V DC power input and the other input and output signals.
Trigger input and sync input/output signals can be assigned through the camera setting communication.

3. Pin Assignment:

A. Camera Link Connector

Pin No.	Signal name	Pin No.	Signal name
1	GND	14	GND
2	X0-	15	X0+
3	X1-	16	X1+
4	X2-	17	X2+
5	Xclk-	18	Xclk+
6	X3-	19	X3+
7	SerTC+	20	SerTC-
8	SerTFG-	21	SerTFG+
9	CC1- (TRG)	22	CC1+ (TRG)
10	CC2+	23	CC2-
11	CC3-	24	CC3+
12	CC4+	25	CC4-
13	GND	26	GND

B. Interface Connector

Pin No.	Signal name	IN/OUT	Voltage
1	GND	IN	0V
2	I/O-1	IN/OUT	+3.3V
3	I/O-2	IN/OUT	+3.3V
4	I/O-3	IN/OUT	+3.3V
5	TRG Out	OUT	+3.3V
6	+12V	IN	+12V

Notes:

Trigger input signal can be assigned either on Camera Link connector (CC1) or on the No. 2 pin of the interface connector through the camera setting communication.

The external sync signals (HD and VD) can be assigned on the following connectors through the camera setting communication.

Camera Link connector (CC2: HD signal input, CC3: VD signal input) or
6pin interface connector (No.4: HD signal input / output, No3: VD signal input / output)

II. Dimensions

A. Dimensions

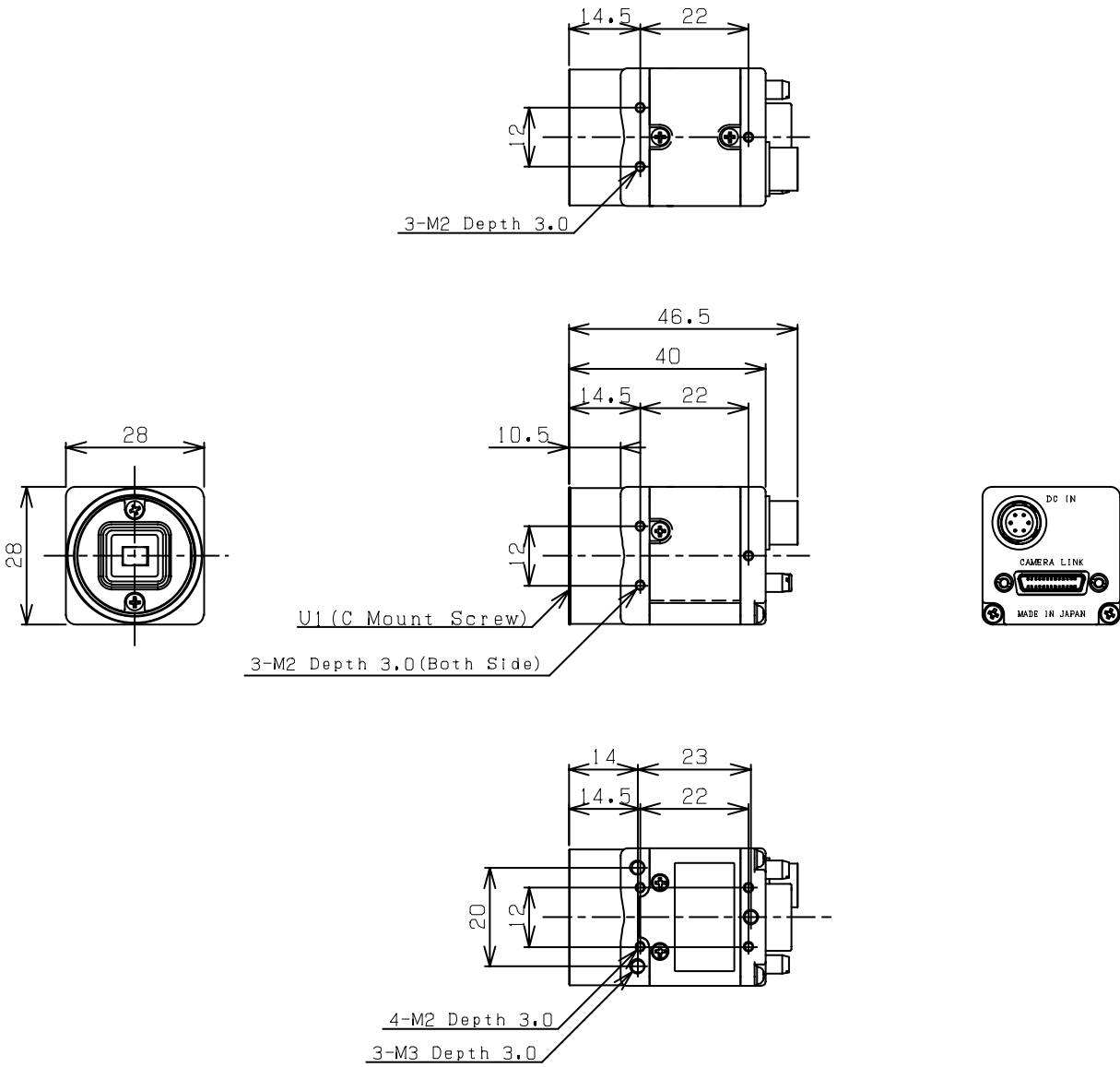

Unit: mm

B. Tripod Dimensions

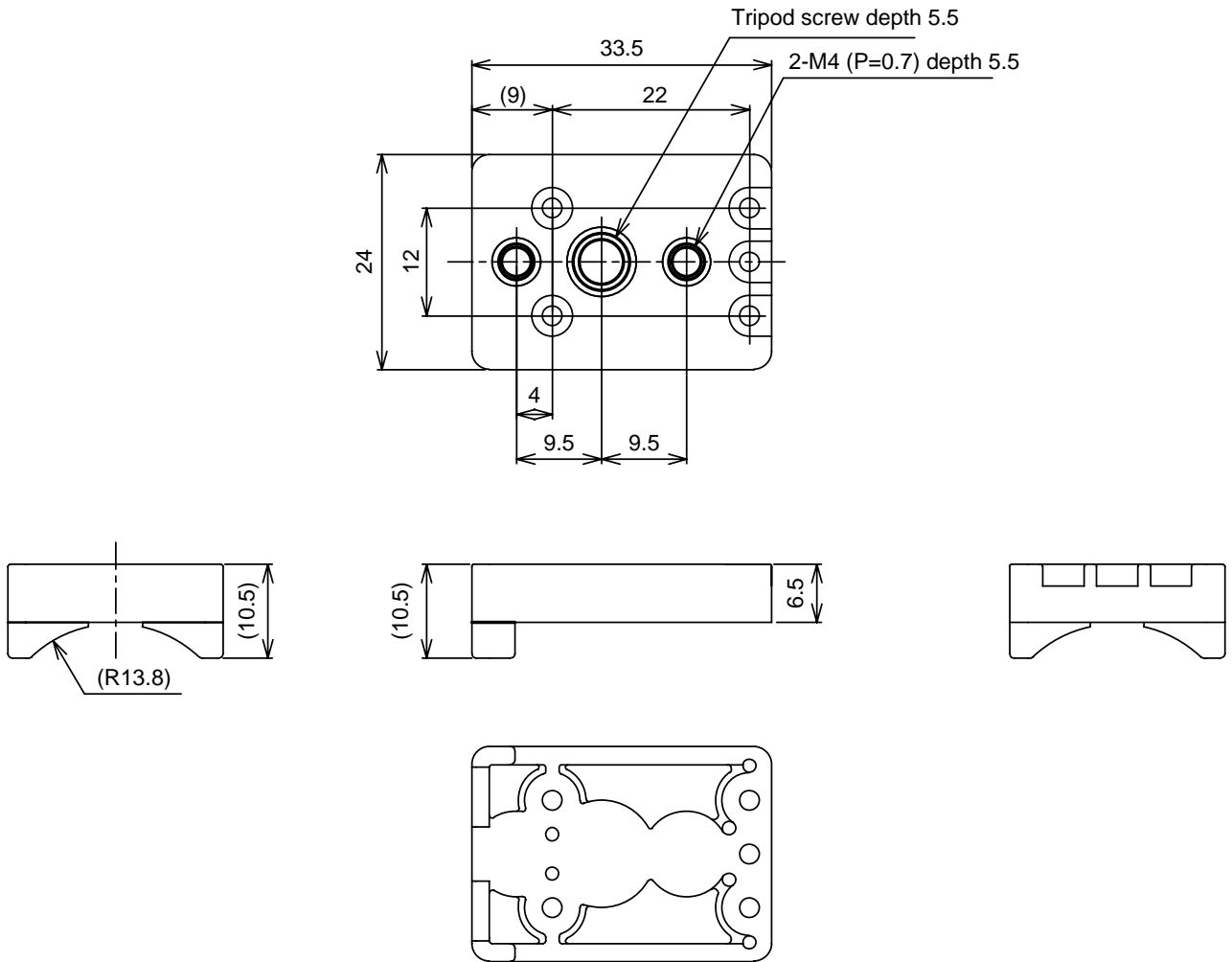

Unit: mm

C. Dimensions (Camera with Tripod)

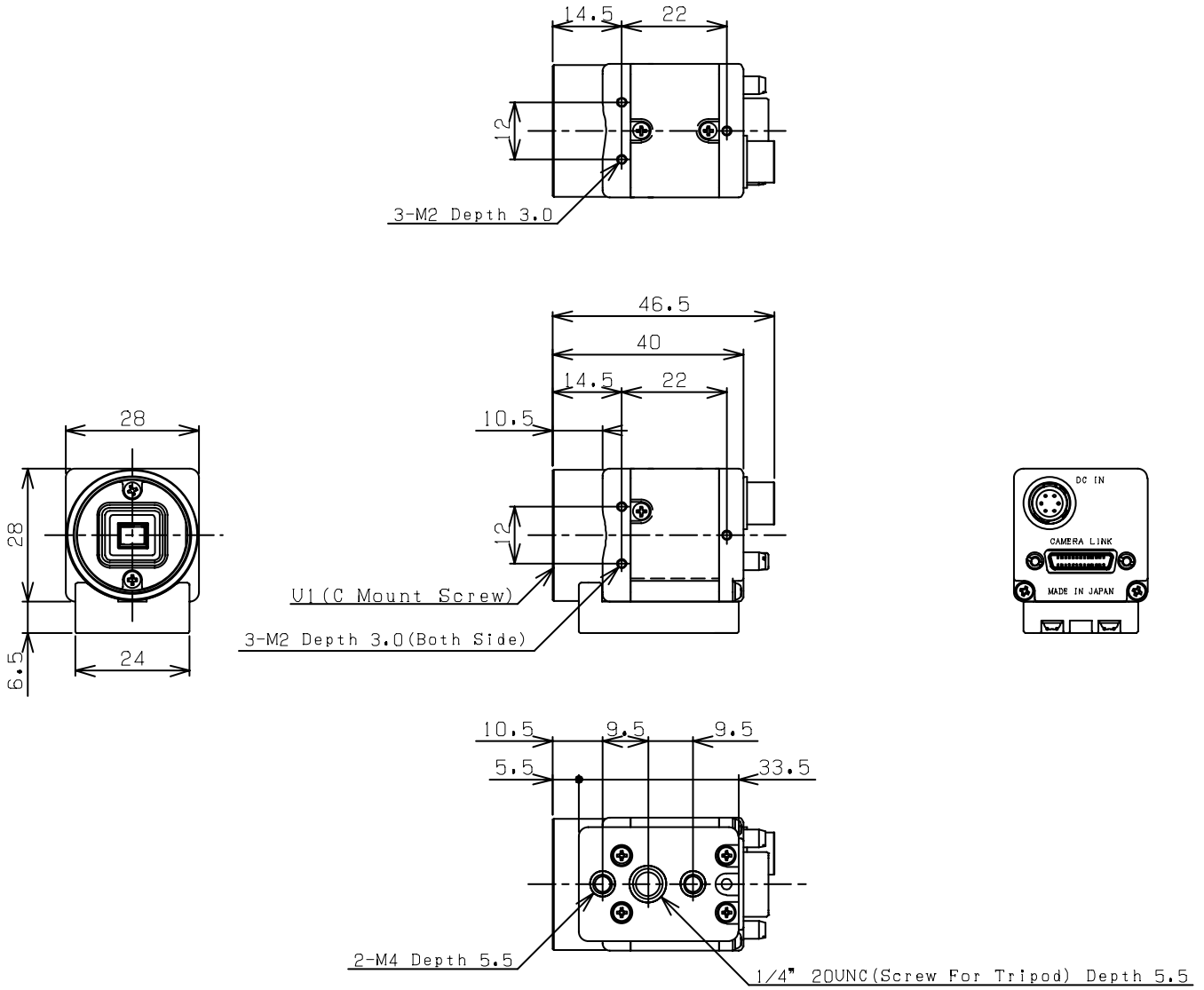

Unit: mm

Revisions

Revision	Date (D/M/Y)	Changes	Name	Changes
1.0	19/06/2006	Created Document	Sam Aimonio	
1.1	22/08/2006	Update whole document	Sam Aimonio	
1.2	14/09/2006	Update 1) Electronic specification	Sam Aimonio	
1.3	21/10/2006	Update 1) Horizontal output timing chart	Sam Aimonio	
1.4	25/04/2007	Update 1) Video output timing chart	Sam Aimonio	
1.5	1/10/2007	Update 1) Mechanical specifications 2) Communication specifications 3) Tripod drawing 4) Camera modes	Sam Aimonio	
2.0	16/4/2008	Separate document from "Specification" to "Specification" and "User's guide"	Sam Aimonio	
2.1	13/5/2008	Edited English	Michelle Campbell	

Sensor Technologies America, Inc.

1345 Valwood Pkwy, Suite 320
Carrollton, Texas 75006-6891
TEL (972) 481-9223 FAX (972) 481-9209
URL <http://www.sentechamerica.com/>

Sensor Technology Co., Ltd.

7F, Harada Center Building
9-17, Naka cho 4chrome
Atsugi-city, Kanagawa
243-0018 Japan
TEL +81-46-295-7061 FAX +81-46-295-7066
URL <http://www.sentech.co.jp/>

Taiwan Sensor Technology, Inc.

3F-6, No. 9, Aiguo W, Rd., Jhong Jheng District
Taipei City 100, Taiwan, R.O.C.
TEL 886-2-2383-2331 FAX 886-2-2370-8775
EMAIL: sentech0501@yahoo.com.tw