

High Sensitivity and Superb Picture Quality for Surveillance Monitoring, Police Vehicle, and Inspection Applications

Sony continues to add choice and flexibility to its FCB Series with the introduction of FCB-EX20D and FCB-EX20DP cameras. The FCB-EX20D/EX20DP incorporates a newly designed 1/3-type Super HAD™ CCD II sensor that provides increased sensitivity compared to cameras featuring the successful 1/4 Super HAD CCD. The camera can operate under a minimum illumination of 0.25 lx. When combining Sony's advanced Digital Signal Processing technology with this new CCD, the FCB-EX20D/EX20DP achieves a horizontal resolution of 530 TV lines, providing extremely clear and detailed images.

Featuring a Day/Night function, the camera offers optimized sensitivity in changing light conditions, which is a typical challenge for 24/7/365 surveillance monitoring applications. In addition, the camera provides an extremely wide horizontal angle of view (5.4° to 50°) with a 120x zooming capability for exceptionally close inspection to capture detailed information. Moreover, to further improve camera performance, the FCB-EX20D/EX20DP offers a number of sophisticated functions such as advanced spherical privacy zone masking with a mosaic effect, video motion detection, multi-line on-screen display, and slow AE function.

When utilized in a fixed-type, mini speed-dome, or as a Pan/Tilt/Zoom (P/T/Z) camera, the FCB-EX20D/EX20DP is the definitive choice for security and monitoring systems. These cameras are so versatile that they can be used in video conferencing and low vision systems, to police vehicles and underground inspection (oil and gas pipelines).



Color Block Cameras

FCB-EX20D/FCB-EX20DP

FEATURES

Excellent Picture Quality, High-Resolution Images

The FCB-EX20D/EX20DP incorporates the newly developed Super HAD CCD II sensor that offers highly improved sensitivity and color reproduction compared to earlier Super HAD CCDs. In addition, the camera can operate with a minimum illumination of 0.25 lx, resulting in a significant improvement in image quality under limited lighting conditions. By combining a powerful DSP with this new CCD, the camera achieves a high horizontal resolution of 530 TV lines.

Day/Night Function

The FCB-EX20D/EX20DP features a Day/Night capability, which provides optimum sensitivity in both day and night shooting applications. As the scene illumination darkens, the infrared filter is automatically removed. The camera then switches to B&W mode enabling it to operate under a minimum illumination of 0.0004 lx (Auto ICR On).

Compact and Lightweight Design

With the compact and lightweight (approx. 140 g/5 oz) design, the camera can be integrated into a variety of space-restricted environments.

Slow AE Response Function – Ideal for Abrupt Lighting Condition Changes

The FCB-EX20D/EX20DP is equipped with a slow AE response function to automatically slow the rate at which camera exposure levels change. The rate can be set up to 32 times slower than when Full-Auto AE or Priority (shutter/iris) modes are selected. This function is essential for monitoring applications when lighting conditions change abruptly, such as night time traffic monitoring.

Advanced Spherical Privacy Zone Masking with Mosaic Effect

In addition to conventional color masking, unwanted or prohibited areas within an image can be masked using a mosaic effect. When the camera is installed in a Pan/Tilt/Zoom (P/T/Z) camera system, masking areas are interlocked with P/T/Z movements, regardless of the camera angle or movement.

Powerful and Versatile Zoom Capability

The FCB-EX20D/EX20DP incorporates a 10x zoom lens. When used in combination with its 12x digital zoom, the camera achieves a zooming capability of up to 120x.

Multi-line On-screen Display

The FCB-EX20D/EX20DP camera can display up to eleven lines with 20 characters per line on the monitoring screen by using VISCA™ commands. Captions can be displayed on screen to provide operators with a user-friendly interface.

Other Features

- Video Motion Detection
- Electronic-Flip (e-Flip)
- Picture Freeze
- SMART (Sony Modular Automatic lens Reset Technology) Lens Control
- Electronic Shutter/Slow Shutter (1 to 1/10,000 s, 22 steps)
- High-speed Serial Interface (maximum 38.4 kb/s) with TTL Signal-level Control (VISCA protocol)
- Customizable Settings
- Internal/External Sync
- 16 Bytes of Memory (for storing data such as the product serial number and camera/system ID number)

SPECIFICATIONS

	FCB-EX20D	FCB-EX20DP
Image sensor	1/3-type Super HAD CCD II	
Signal system	NTSC	PAL
Number of total pixels	Approx. 380,000 pixels	Approx. 440,000 pixels
Lens	10x optical zoom, f=5.1 mm (wide) to 51.0 mm (tele), F1.8 to F2.1	
Digital zoom	12x (120x with optical zoom)	
Horizontal resolution	On / Off (On: 530 TV lines)	
Angle of view (H)	50.0° (wide end) to 5.4° (tele end)	
TV distortion	4.2 %	
Minimum working distance	15 mm (wide end) to 800 mm (tele end)	
Sync system	Internal / External (V-lock)	
Minimum illumination	1/60 s, 1/50 s mode: 0.25 lx (typical) (F1.8, 50 IRE) 1/4 s, 1/3 s mode: 0.015 lx (typical) (F1.8, 50 IRE) 1/4 s, 1/3 s mode & ICR on: 0.0004 lx (typical) (F1.8, 50 IRE)	
S/N ratio	More than 50 dB	
Electronic shutter	1/1 to 1/10,000 s, 22 steps	
White balance	Auto, ATW, Indoor, Outdoor, One-push, Manual	
Gain	Auto / Manual (-3 to 28 dB, 2 dB steps)	
AE control	Auto, Manual, Priority mode, Bright, EV compensation, Backlight compensation, Slow AE	
EV compensation	-10.5 to 10.5 dB (1.5 dB steps)	
Back-light compensation	On / Off	
Privacy zone masking	On / Off (24 positions, 8 positions per screen, 14 colors & mosaic)	
Character generator	Mode display: On / Off (White Balance, Gain, etc.) Title display: Max. 11 lines (20 characters per line)	
Flicker cancel	Auto	
Focusing system	Auto (Sensitivity: normal, low), One-push AF, Manual, Infinity, Interval AF, Zoom trigger AF	
Picture effects	E-Flip, Nega Art, Black&White, Mirror Image	
Video output	VBS: 1.0 Vp-p (sync negative), Y/C	
Camera control interface	VISCA (TTL signal level), baud rate: 9.6 Kb/s, 19.2 Kb/s, 38.4 Kb/s, 1 or 2 Stop bit selectable	
Storage temperature	-20 °C to 60 °C	
Operating temperature	0 °C to 50 °C	
Power consumption	6 to 12 V DC / 2.4 W (motors inactive), 6.5 W (motors active)	
Weight	5 oz (140 g)	
Dimensions (w x h x d)	1 13/16 x 1 3/4 x 2 3/4 inches (45.9 x 43.1 x 67.2 mm)	

DIMENSIONS

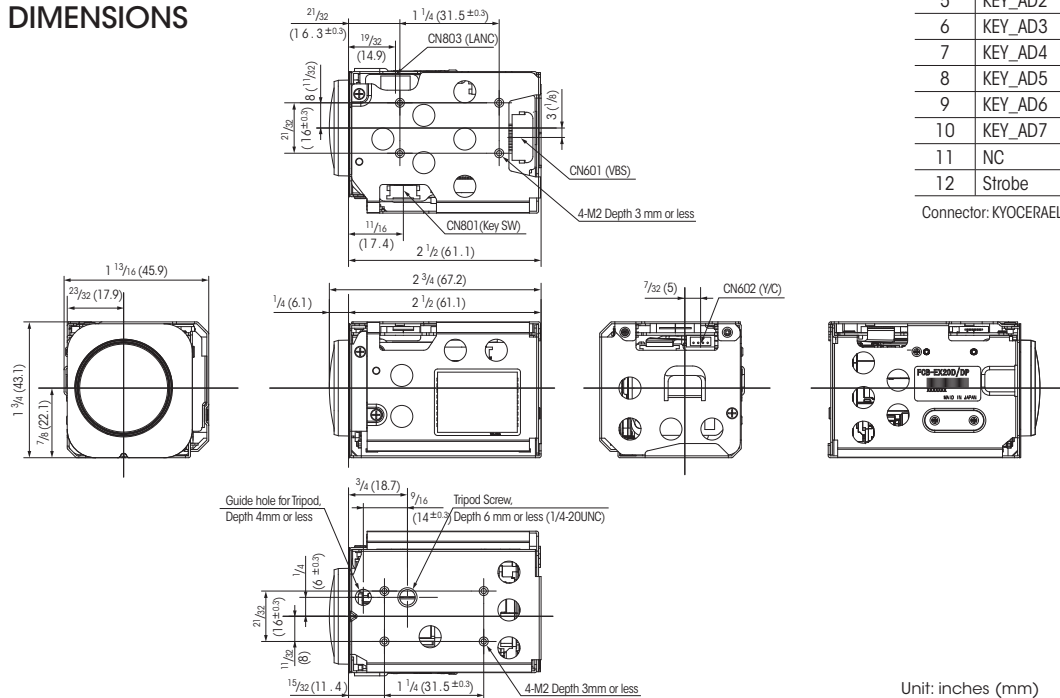

PIN ASSIGNMENT & CONNECTOR

CN602 4-pin for Y/C Video Out

Pin No.	Name	Level
1	Y_OUT	1.0 Vp-p (75 Ω terminate) Luminance signal
2	GND (for Y signal)	
3	C_OUT	Chrominance signal
4	GND (for C signal)	

Connector: JST S4B-ZR-SM4A-TF (LF)

CN601 9-pin for DC/Video Out

Pin No.	Name	Level
1	RxD	TTL/CMOS Level Read Data
2	TxD	TTL/CMOS Level Send Data
3	GND (for RxD&TxD)	
4	DC IN	9.0 V ± 3.0 V
5	GND (for DC IN)	
6	VBS OUT	1.0 Vp-p (75 Ω terminate)
7	GND (for VBS OUT)	
8	V LOCK PULSE	External VD-Lock Pulse (EX.FV: Negative, 3.0 Vp-p 50% duty)
9	GND (VL PULSE)	

Connector: KYOCERAELCO 00 6200 509 130 000+

CN801 12-pin for Key Switch control

Pin No.	Name	Level
1	GND	
2	GND	
3	KEY_AD0	Pull up to 3.0 V by 100 kΩ
4	KEY_AD1	Pull up to 3.0 V by 100 kΩ
5	KEY_AD2	Pull up to 3.0 V by 100 kΩ
6	KEY_AD3	Pull up to 3.0 V by 100 kΩ
7	KEY_AD4	Pull up to 3.0 V by 100 kΩ
8	KEY_AD5	Pull up to 3.0 V by 100 kΩ
9	KEY_AD6	Pull up to 3.0 V by 100 kΩ
10	KEY_AD7	Pull up to 3.0 V by 100 kΩ
11	NC	
12	Strobe	Strobe timing pulse (0 to 3 V)

Connector: KYOCERAELCO 086222012101848+

Unit: inches (mm)

SONY

Sony Electronics Inc.
1 Sony Drive
Park Ridge, NJ 07656
201-930-7000
www.sony.com/videocameras
IS-1214 (MK10531V1)

© 2008 Sony Corporation. All rights reserved.
Reproduction in whole or in part without written permission is prohibited.
Design, features, and specifications are subject to change without notice.
All non-metric weights and measurements are approximate.
Sony, Super HAD, and VISCA are trademarks of Sony Electronics Inc.

Printed in USA (10/08)