

**SENTECH**

**STC-CL/CLC152A**  
**Specification Manual**

Small Cubic Type - SXGA CCD  
Color / Monochrome Camera Link Camera

## Contents

I. Specifications	
A. Electronic Specs / Mechanical Specs / Environmental Conditions.....	1
B. Connector Specifications.....	2
1. Camera Link Connector.....	2
2. Interface Connector.....	2
3. Pin Assignments.....	2
II. Dimensions	
A. Dimensions.....	3
B. Dimensions (Tripod).....	4
C. Dimensions (Camera with Tripod).....	5

## I. Specifications

### A. Electronic Specifications / Mechanical Specifications / Environmental Conditions

Product		STC-CLC152A	STC-CL152A	
Electronic specifications	Imager	1/2" interline SXGA color progressive CCD: ICX205AK	1/2" interline SXGA monochrome progressive CCD: ICX205AL	
	Total picture elements	1434 (H) x 1050 (V)		
	Effective picture elements	1392 (H) x 1040 (V)		
	Effective picture elements	SXGA: 1360 (H) x 1024 (V)		
	Chip size	7.6 (H) x 6.2 (V) mm		
	Cell size	4.65 (H) x 4.65 (V) $\mu$ m		
	Scanning system	Progressive		
	Scanning method	Full scanning, Partial full scanning, 1/2 partial scanning, 1/4 partial scanning, Variable partial scanning	Full scanning, Partial full scanning, 1/2 partial scanning, 1/4 partial scanning, Variable partial scanning, Binning, Binning partial scanning, Binning 1/2 partial scanning, Binning 1/4 partial scanning, Binning variable partial scanning	
	Vertical frequency (Frame rate)	15.28 (15fps) / 19.3 (19fps) Hz		
	Horizontal frequency	15.998 (15fps) / 20.57 (19fps) kHz		
	Pixel frequency	28.6363 (15fps) / 36.8181 (19fps) MHz		
	S/N ratio (standard deviation)	$\leq$ 10 Digit (Gain 0 dB)		
	Minimum scene illumination	2 Lux at F1.4	1 Lux at F1.4	
	Sync. System	Internal / External		
	Video output	Digital 8 or 10 bit Camera Link (Base configuration)		
	Tap	1 Tap		
	Shutter speed	OFF, 1/2 to 1/100,000 sec. (Variable at every H and clock)		
	Gain	0 to 27 dB		
	Gamma	1.0		
	Power supply	Input voltage	DC12V $\pm$ 10%	
Consumption		Less than 2.5 W		
Trigger mode	Edge preset trigger (V-reset, Non-reset) Pulse width trigger (V-reset, Non-reset)			
Communication	RS232 via Camera Link connector			
Mechanical specifications	Dimensions	28 (W) x 28 (H) x 46.5 (D) mm including lens mount and the connector		
	Optical filter	No IR cut filter		
	Optical center accuracy	Positional accuracy in H and V directions: $\pm$ 0.31 mm Rotational accuracy of H and V: $\pm$ 2.1 deg.		
	Material	Case	Front, base and rear: Aluminum die cast (ADC12) Cover: Steel sheet covered with zinc	
		Tripod	Polycarbonate ABS	
	Lens mount	C mount		
	Interface connector	HR10A-7R-6PB (Hirose) or equivalent		
	Tripod	Tripod can be attached to 4 plates (4 screws on the bottom plate, 3 screws on the other 3 plates)		
	Weight	Approximately 52 g (Camera: 43 g, tripod: 9 g)		
	Environmental conditions	Temperature and humidity	Operational	Temperature: -5 to 45 deg. C, RH: 0 to 85% (No condensation)
Storage			Temperature: -30 to 65 deg. C, RH: 0 to 90% (No condensation)	
Vibration		20Hz to 200Hz to 20Hz (5min./cycle), acceleration 10G, 3 directions 30 min. each		
Shock		Acceleration 70G, half amplitude 6ms, 3 directions 3times each		
Standard compliancy		EMS: EN61000-6-2, EMI: EN55011 (Class B)		
RoHS		RoHS compliance		

## B. Connector Specifications

1. Camera Link Connector: SCR (3M) or equivalent

**Caution: This product is not PoCL type. Only apply 12V power through the interface connector.**

2. Interface Connector: HR10A-7R-6PB (Hirose) or equivalent  
This connector is for a 12v DC power input and the other input and output signals.  
Trigger input and sync input/output signals can be assigned through the camera setting communication.

### 3. Pin Assignment:

#### A. Camera Link Connector

Pin No.	Signal name	Pin No.	Signal name
1	GND	14	GND
2	X0-	15	X0+
3	X1-	16	X1+
4	X2-	17	X2+
5	Xclk-	18	Xclk+
6	X3-	19	X3+
7	SerTC+	20	SerTC-
8	SerTFG-	21	SerTFG+
9	CC1- (TRG)	22	CC1+ (TRG)
10	CC2+	23	CC2-
11	CC3-	24	CC3+
12	CC4+	25	CC4-
13	GND	26	GND

#### B. Interface Connector

Pin No.	Signal name	IN/OUT	Voltage
1	GND	IN	0V
2	I/O-1	IN/OUT	+3.3V
3	I/O-2	IN/OUT	+3.3V
4	I/O-3	IN/OUT	+3.3V
5	TRG Out	OUT	+3.3V
6	+12V	IN	+12V

#### Notes:

Trigger input signal can be assigned either on Camera Link connector (CC1) or on the No. 2 pin of the interface connector through the camera setting communication.

The external sync signals (HD and VD) can be assigned on the following connectors through the camera setting communication:

Camera Link connector (CC2: HD signal input, CC3: VD signal input) or  
6pin interface connector (No.4: HD signal input / output, No3: VD signal input / output)

## II. Dimensions

### A. Dimensions

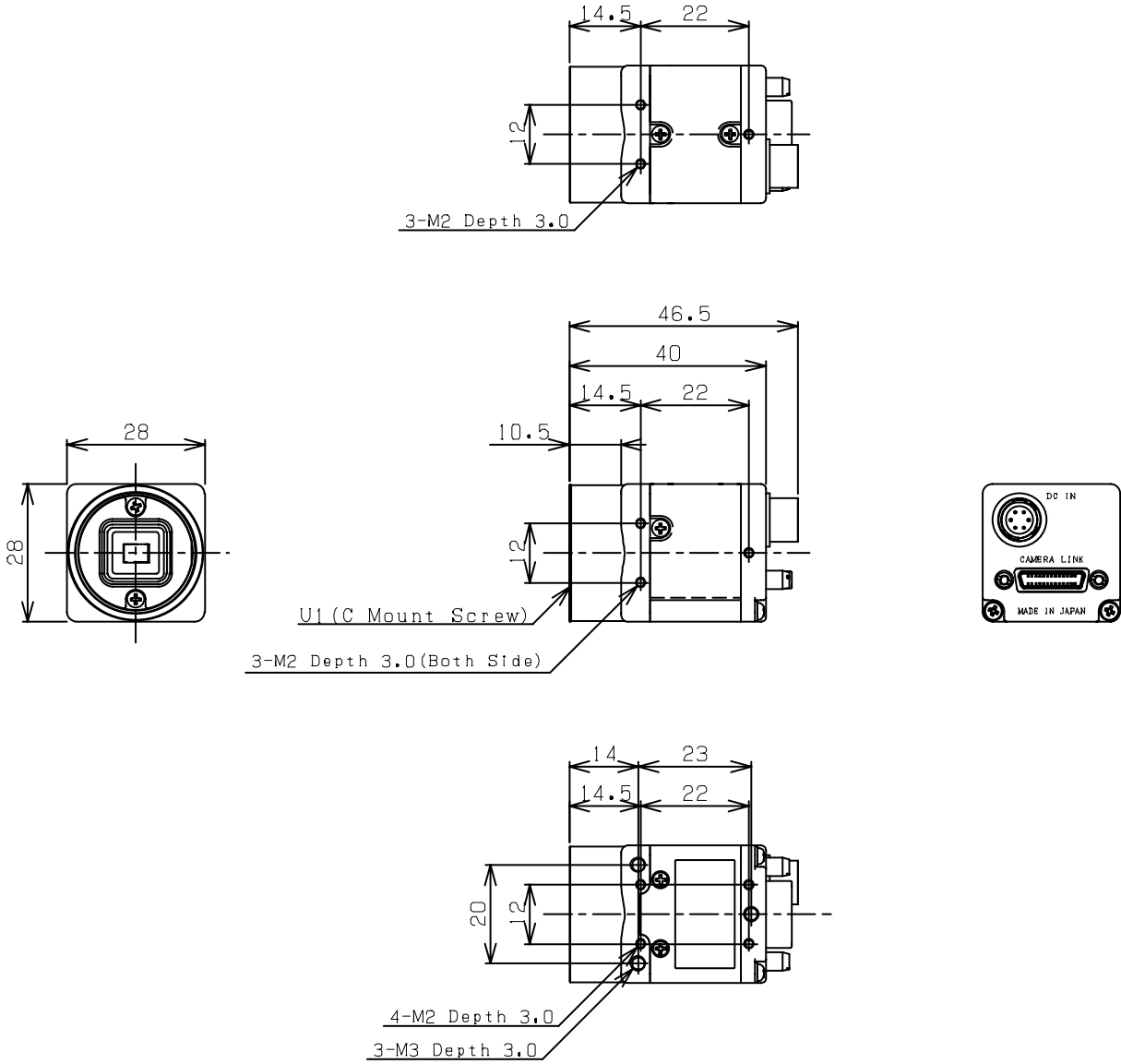

Unit: mm

## B. Tripod Dimensions

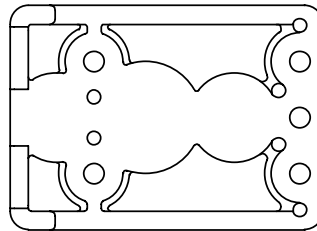
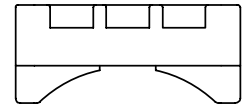
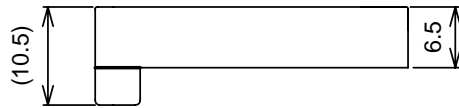
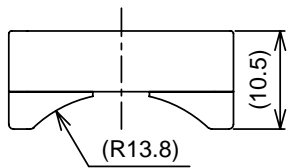
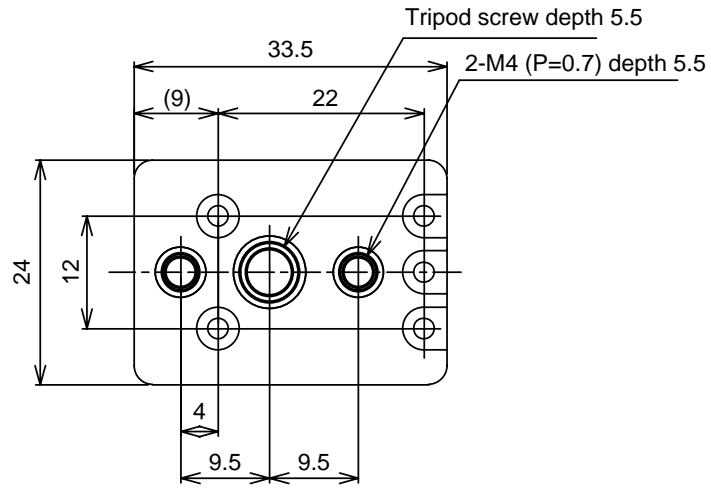

Unit: mm

## C. Dimensions (Camera with Tripod)

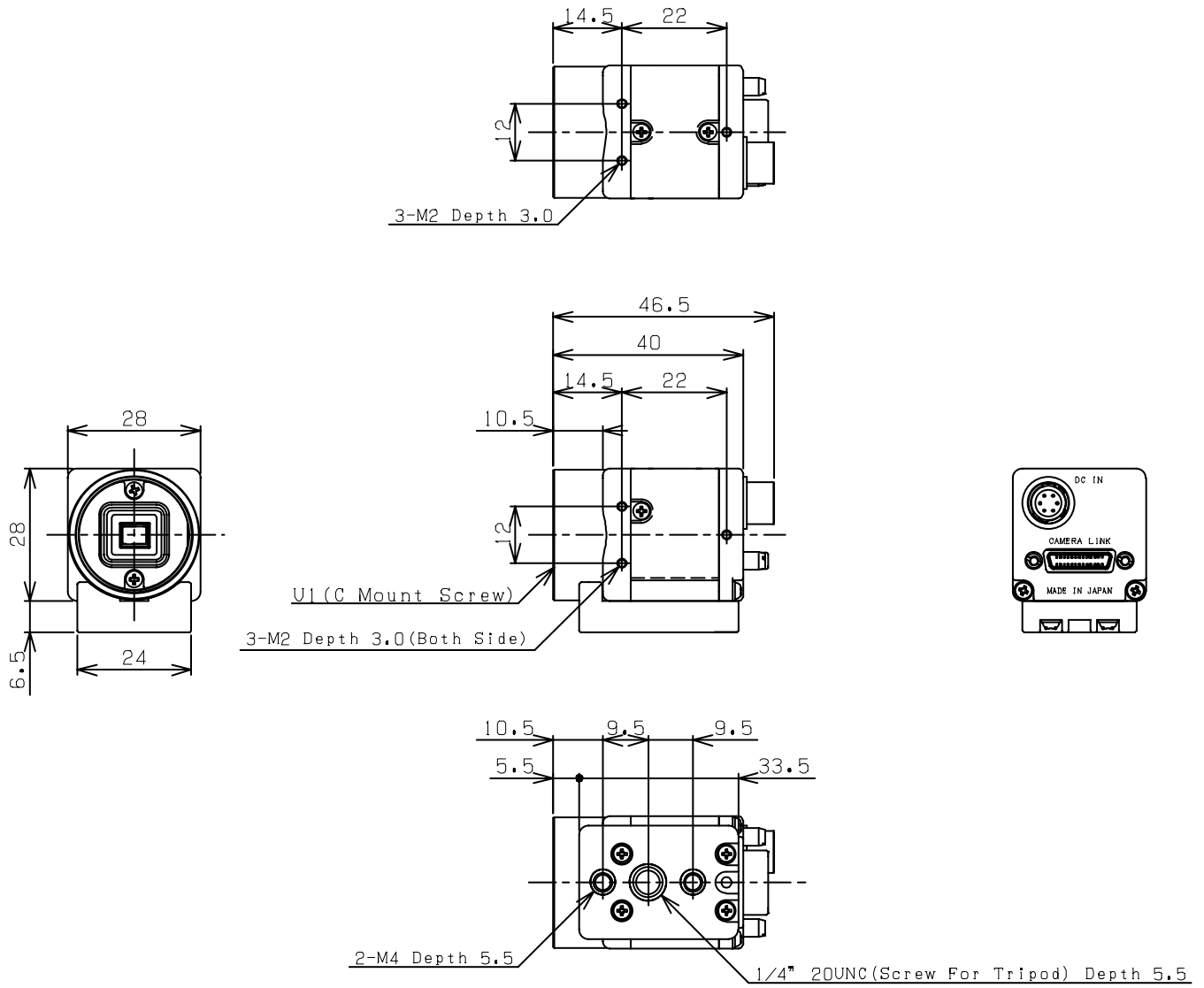

Unit: mm

## Revisions

Revision	Date (D/M/Y)	Changes	Name	Changes
1.0	19/06/2006	Created Document	Sam Aimono	
1.1	16/04/2007	Update 1) Mechanical Specs (optical center accuracy) 2) Communication Specs (Add the initial data and the data range)	Sam Aimono	
2.0	16/04/2008	Separate document from "Specification" to "Specifiacion" and "User's Guide"	Sam Aimono	
2.1	12/05/2008	Edited English	Michelle Campbell	

**Sensor Technologies America, Inc.**

1345 Valwood Pkwy, Suite 320  
Carrollton, Texas 75006-6891  
TEL (972) 481-9223 FAX (972) 481-9209  
URL <http://www.sentechamerica.com/>

**Sensor Technology Co., Ltd.**

7F, Harada Center Building  
9-17, Naka cho 4chrome  
Atsugi-city, Kanagawa  
243-0018 Japan  
TEL +81-46-295-7061 FAX +81-46-295-7066  
URL <http://www.sentech.co.jp/>

**Taiwan Sensor Technology, Inc.**

3F-6, No. 9, Aiguo W, Rd., Jhong Jheng District  
Taipei City 100, Taiwan, R.O.C.  
TEL 886-2-2383-2331 FAX 886-2-2370-8775  
EMAIL: sentech0501@yahoo.com.tw