

# FOculus

*Always a new perspective*



## FO442SBISC

[www.net-gmbh.com](http://www.net-gmbh.com)

### IEEE1394 Digital CCD Camera

- *2/3" Progressive Scan CCD Image Sensor*
- *Resolution 1,450,000 (square pixel) SXGA*
- *IEEE1394.a acc. IIDC v.1.31 Interface*
- *FO442SB =BIW • FO442SC =Color*
- *External Trigger*
- *Frame Rate 20fps*
- *Partial Scan*
- *Camera setting via IEEE1394 Interface*
- *Opto - Isolated I/O*
- *Compact, solid and highly shock-resistant casing*
- *Industrial Lock Screw Support*
- *Application:*
  - *Machine Vision*
  - *Semi Con Inspection*
  - *Factory Automation*
  - *Microscopy + Medical*
  - *Quality Control*
  - *Barcode, OCR, OCV*
- *Free Application Software and SDK*

  
*NEW ELECTRONIC TECHNOLOGY*

# Technical Data

# FO442SB/SC

	FO442SB (B/W)	FO442SC (Color)
Image Sensor	2/3" IT CCD ICX285AL	2/3" IT CCD ICX285AK
Effective pixel	1.450,000 pixel, 1392 (H) x 1040 (V) SXGA	
Data Path	8bit or 12bit B/W	8bit or 12bit Raw RGB / YUV422
Pixel Size	6.45 (H) x 6.45 (V) $\mu$ m	
Scanning System	Progressive Scan	
Frame Rate	20fps (format7) / 15 / 7.5 / 3.75 / 1.875 fps	
Synchronization	Internal	
Digital Interface	IEEE1394a	
Software Interf.	Acc. IIDC v. 1.31	
Gain Control	Manual: 0 ~ 25 dB; Auto Gain	
Gamma	0.4 ~ 2.5	
Strobe Output	Yes	
S/N Ratio	56 dB or better	
Power Supply	+ 8 VDC to + 30 VDC via the IEEE1394 cable	
Transfer Rate	400 Mbps	
Trigger Mode	Software or External Trigger / Mode 0 ~ 5; 14	
Shutter Speed	Manual: 1 $\mu$ sec ~ 65 sec; Auto Shutter	
Advanced Features	Pixel Binning (only B/W); RS232 (SIO/Pass through); ROI; One Shot & Multi Shot; Multi Camera Auto Sync; Opto-Isolated I/O; Industrial Lock Screw Support	
Operating Temperatur	- 5°C to + 45°C	
Regulations	FCC, CE, RoHS	
Lens Mount	C-mount	
Dimension	44 (W) x 29 (H) x 63 (D)mm / Approx. 110g	

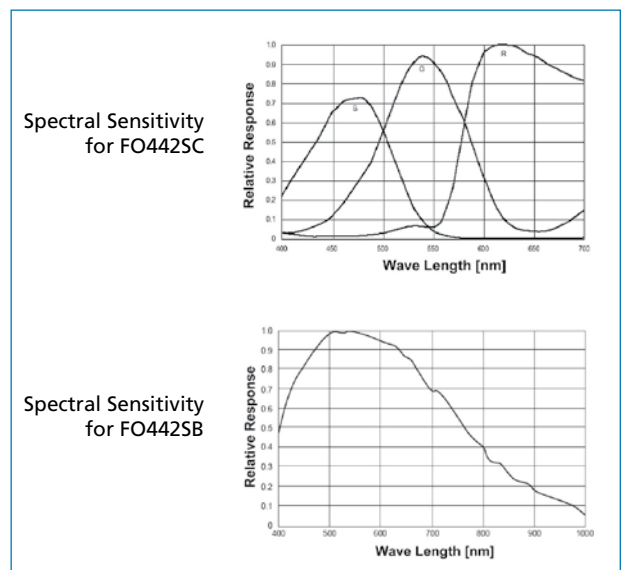
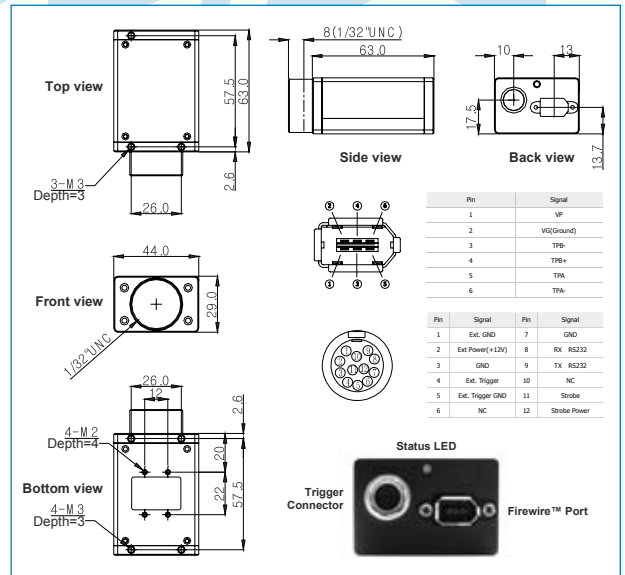

**Accessories:** • IEEE 1394 cable, 6-pin • SDK (Software Development Kit) • OHCI Card • Tripod Adapter Plate • Trigger Cable 12-pin

## Contact

**New Electronic Technology**  
Vertriebsgesellschaft mbH  
Lerchenberg 7 • D-86923 Finning

Fon +49 8806 92 34-0  
Fax +49 8806 92 34-77  
info@net-gmbh.com

[www.net-gmbh.com](http://www.net-gmbh.com)

**NET USA, Inc.**  
3037 - 45th Street  
Highland, IN 46322

Fon +1 219 934 90 42  
Fax +1 219 934 90 47  
info@net-usa-inc.com

[www.net-usa-inc.com](http://www.net-usa-inc.com)

