



72MHz Pixel Clock Camera Link Color Camera

# VCC-F32

Series

VCC-F32U29CL

1/1.8" CCD 30fps

UXGA

VCC-F32S19CL

2/3" CCD 34fps

SXGA

VCC-F32S29CL

1/2" CCD 38fps

SXGA



VCC-F32 series 72MHz pixel clock, high speed color camera

The high speed and non-compressed image output best suited for high-speed inspection applications.

Features switchable digital RGB 24bit / RAW DATA (8bit / 10bit) output.

Product variations F32U29CL: 2M pixel / 30fps F32S29CL: 1.45M pixel / 38fps

F32S19CL: 2/3" near-infrared sensitivity CCD / 34fps

## Features

High Resolution

High Framerate

C Mount

Mini Camera Link Connector

Selectable Digital RGB / RAW Output

External Trigger Shutter

Pulse-width Trigger

Slow Shutter

Partial Scan



72MHz Pixel Clock Camera Link Color Camera

# VCC-F32 Series



## Feature Overview

	VCC-F32U29CL	VCC-F32S29CL	VCC-F32S19CL
Resolution	UXGA	SXGA	SXGA
Sensor Type	1/1.8"CCD	1/2"CCD	2/3"CCD
Power Consumption	4.0W		
Input Voltage	DC+12V ± 10%(Max. voltage not to exceed 15V)		
Operating Conditions	Temperature 0 ~ +40 Humidity 20 ~ 80%		
Weight	Approx.140g		
Lens Mount	C Mount		
Optical Axis Accuracy	Less than (Pixel Center) ± 0.1mm		
Video Output Signal	Digital RGB24bit / Digital RAW Data 8bit/10bit( switchable )		
Effective Number of Pixels	1628(H) × 1236(V)	1392(H) × 1040(V)	1392(H) × 1040(V)
Horizontal Scan Frequency	37.5KHz	40.22KHz	36KHz
Pixel Clock	72MHz		
Pixel Size	4.4 × 4.4( μ m)	4.65 × 4.65( μ m)	6.45 × 6.45( μ m)
Minimum Illumination	F1.4 40lx	F1.4 90lx	F1.4 0.5lx
Sensitivity	F5.6 2000lx	F2.8 2000lx	F16 2000lx
Standard Color Temperature	3200 ° K		
Gain Switching	0dB ,+6dB ,MANUAL(min-1dB ~ max+12dB)		
Electronic Shutter	OFF ~ 1/10000 sec.		
Sync. Method	Internal Sync. External Sync. HD/VD		
External Trigger	Fixed Shutter Exposure/Pulse Width Exposure		
Partial Scan	Programmable Position/Width/Read Position/Number of Lines		
Gamma Compensation	Default OFF		
Control Interface	Camera Link / RS232C(Optional)		
Dimensions	44mm × 29mm × 71.5mm( excluding projection )		

## Dimensions

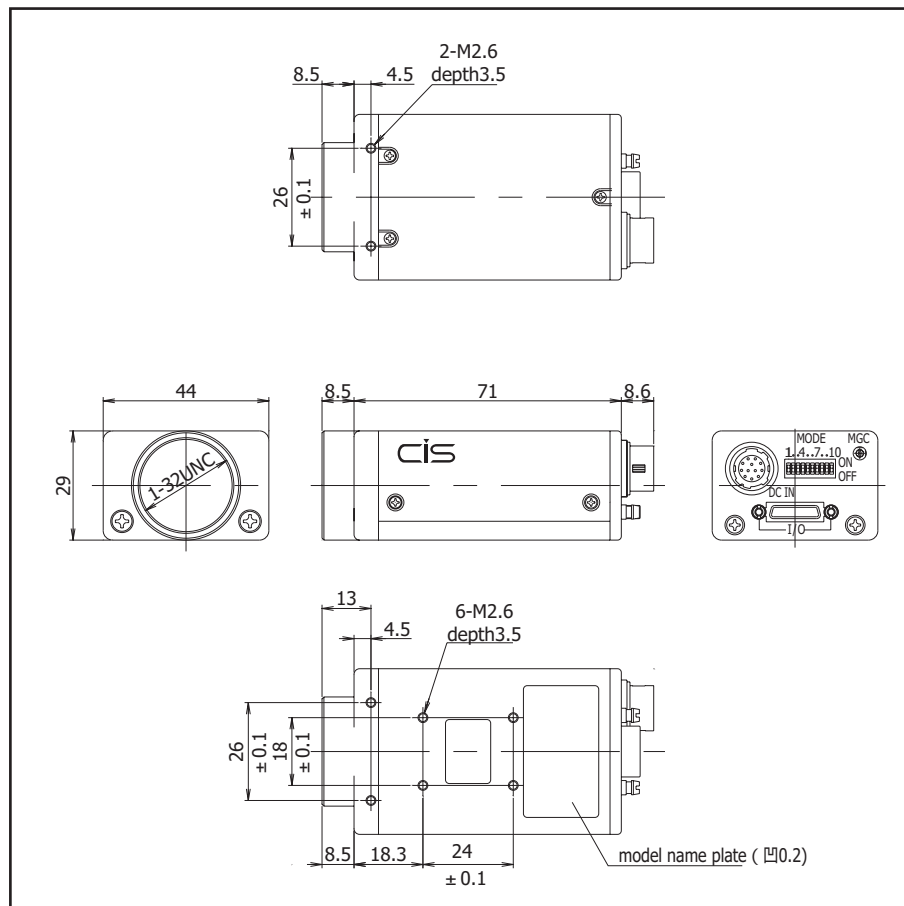

## Important Notice

Information contained herein is subject to change without prior notice.

## Manufacturer

### CIS Corporation

539-5, Higashiasakawa-machi, Hachioji-shi,  
Tokyo, 193-0834 Japan  
TEL. +81-426-64-5535 FAX. +81-426-69-7471  
<http://www.ciscorp.co.jp>

## Authorized Distributor

For further information on the product, please contact your authorized distributor.